

N Monteringsanvisning

UK Assembly Instructions

S Monteringsanvisning

Produkt nr. / Product no. / Produkt nr.

35-100-340

Ordr. nr. _____

Dato. _____

Sign. _____



Søve Lekemiljø AS



Grønnvoldveien 290
3830 Ulefoss - Norway
Tlf: +47 35 94 65 65
www.rove.no

Søve Lekmiljö AB



Fabriksgatan 7
412 50 Göteborg
Tlf: +46 (0) 31 773 97 00
www.rove.se

Dokumentasjon / Documentation/ Dokumentation

(N)

Det er svært viktig sette seg inn i alle skisser og instruksjoner som følger med utstyret som skal monteres!

1. Nødvendig utstyr/ antall personer / arealbehov
2. Planskisse med sikkerhetssone
3. Planoversikt forankring
4. Fundamenteringsanvisning
5. Monteringshøyder fallhøyder
6. Oversikt over festeklammer
7. Monteringsanvisning

NB! Under monteringsarbeidet må utstyret, som ikke er forankret forsvarlig i bakken, avstives slik at det ikke kan velte som følge av vind og lignende, eller ukontrollert bruk. Området må avstenges under oppsettelse av apparatene med sperrebånd og lignende.

(UK)

It is essential that you familiarise yourself first with the plans concerning your structure

1. Necessary equipment/number of people/ area of impact
2. View from above with impact zone.
3. Overview anchoring
4. Anchoring instructions
5. Assemblyheights and critical fallheights
6. Clamps
7. Assembly instructions





NB! During assembly of the equipment, ensure that all structures are securely propped, especially when left overnight. Also ensure that equipment is supported whilst concrete foundations are setting and enclose the area securely to prevent access.

(S)

Det är viktigt att läsa noggrant alla ritningar och instruktioner tillhörande utrustningen som skall monteras

1. Nödvändiga verktyg/ Antal personer/ arealbehov
2. Planritning med säkerhetszon
3. Översikt markförankring
4. Förankringsinstruktion
5. Monteringshöjd och fallhöjd
6. Översikt fästklämmor
7. Monteringsanvisning

OBS! Under monteringsarbete bör utrustningen som inte ska förankras i marken ställas så att det inte kan välta av vind eller liknande. Området måste spärras när lekutrustningen byggs upp, med avspärrningsband eller liknande.

<p>1</p>	<p>Nødvendig verktøy / Tools required / Nödvändiga verktyg</p>				
<p>(N) (UK) (S)</p>		 <p>Torx Nr 45 High quality</p>	 <p>13 mm 17 mm</p>		
<p>(N) (UK) (S)</p>		<p>Merkebånd Mark ribbon Märkband</p> 	<p>18 V</p> 	<p>5 mm</p> 	<p>Metermål Metric measure Tumstock</p> 

<p>1</p>	<p>Nødvendig antall personer / Number of persons required / Lämpligt antal personer</p>		
<p>(N) (UK) (S)</p>	<p>18 t 18 h 18 t</p>		

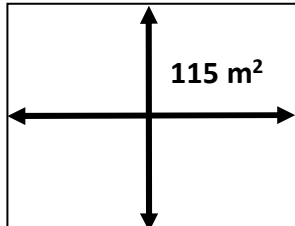
<p>1</p>	<p>Anbefalt arealbehov ved montering / Recommended working space / Rekommenderad arealbehov vid montering</p>
<p>(N) (UK) (S)</p>	

- (N) Forankringsoversikt
- (UK) Anchoringplan
- (S) Förankringsöversikt

DETAIL DE SCÈLEMENT

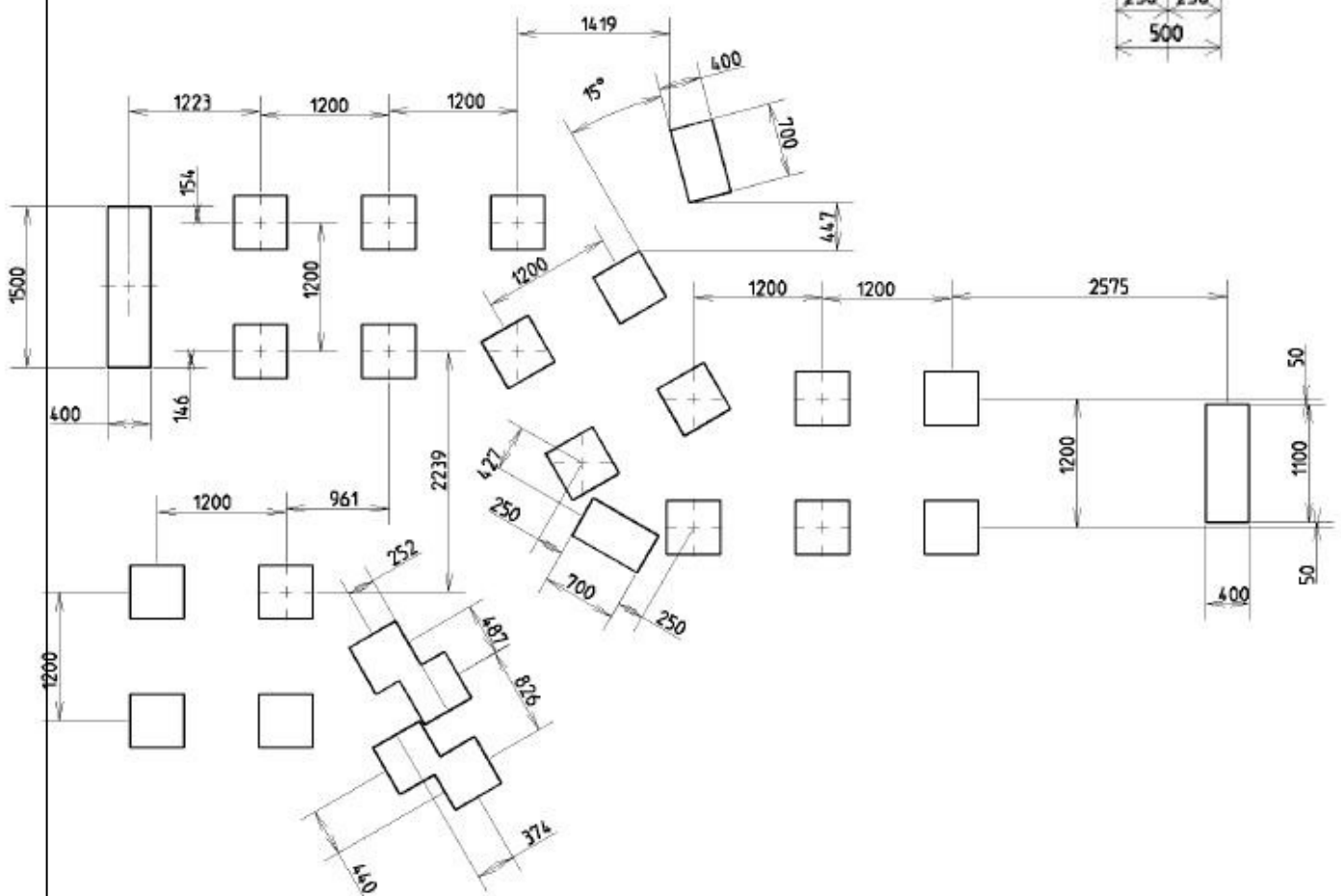
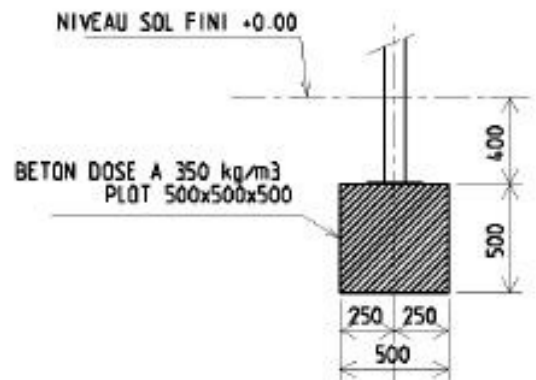

4

(N) Monteringshøyder og fallhøyder

(S) Monteringhöjd och fallhöjd

(UK) Assembly heights and critical fallheights

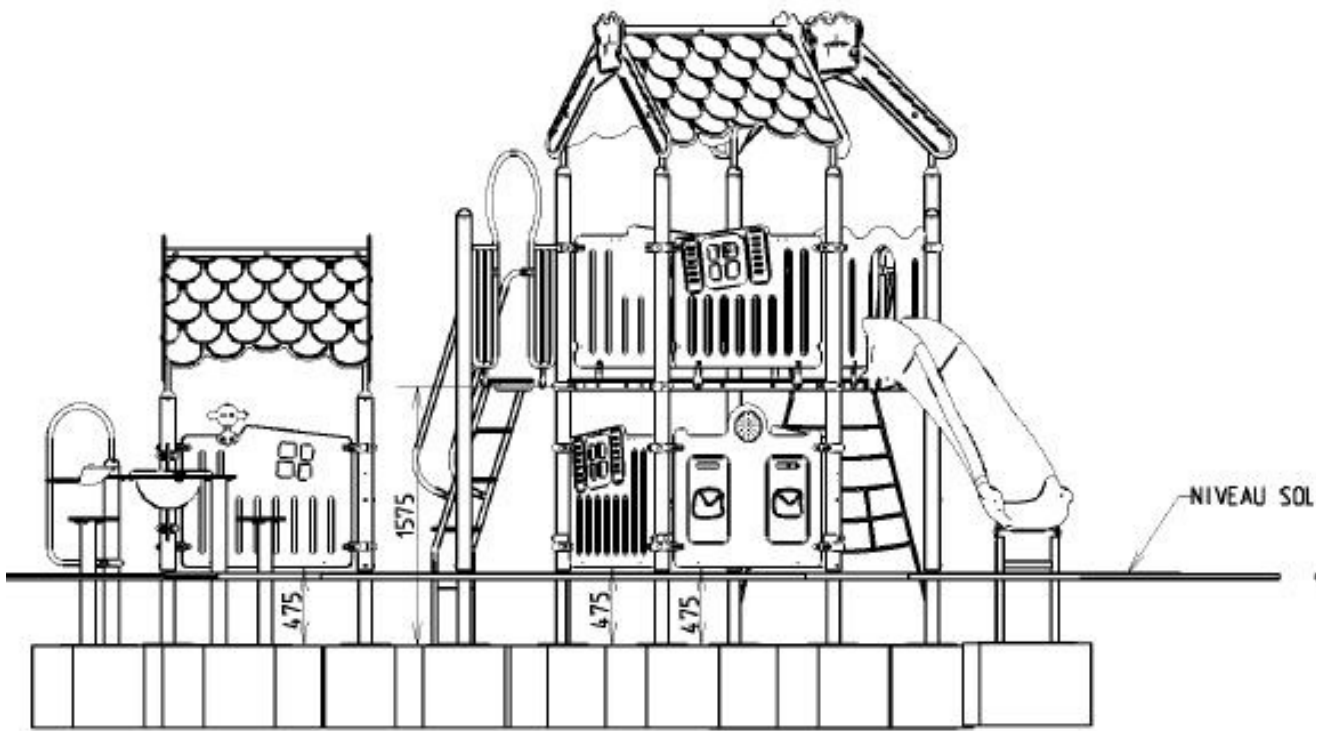

VUE 1

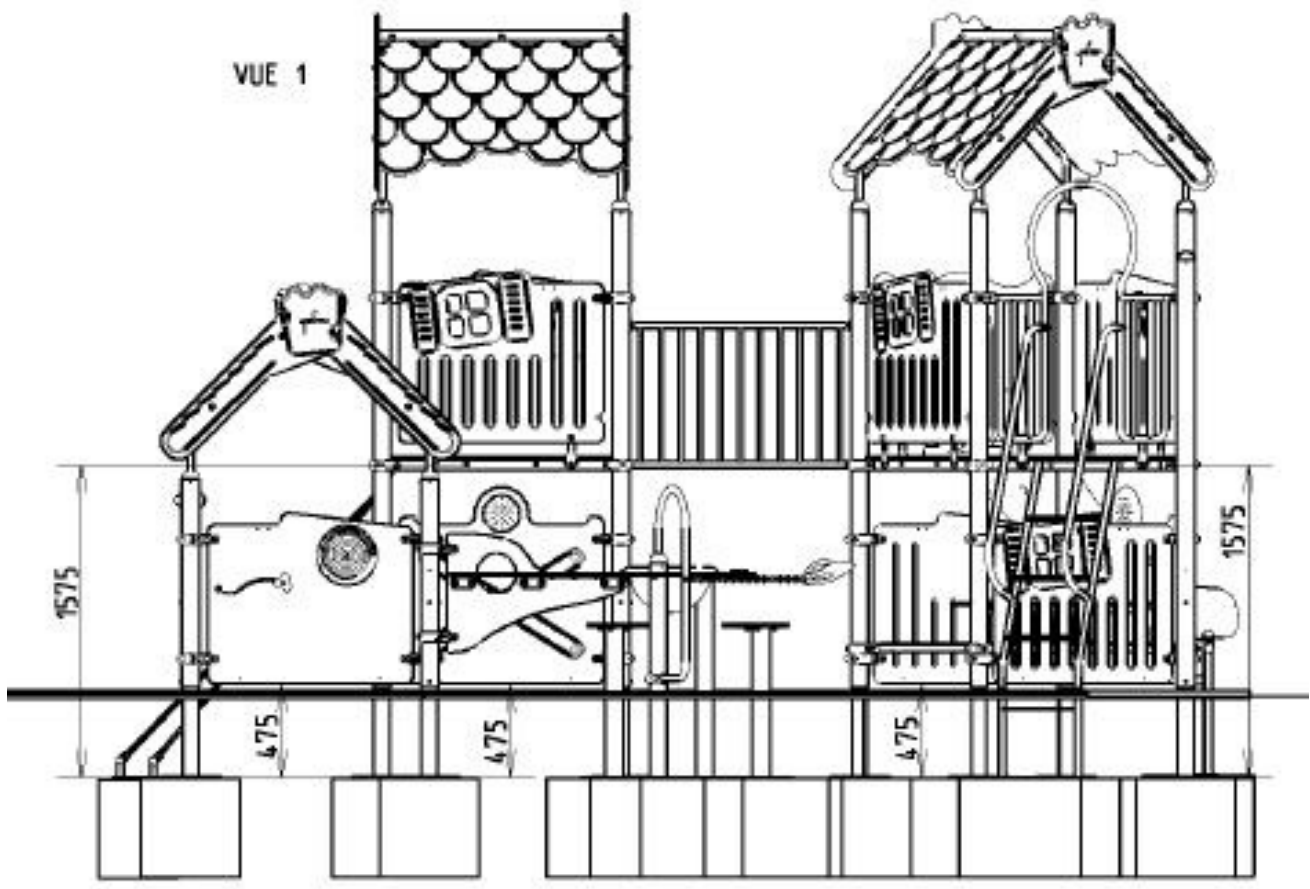

4

(N) Monteringshøyder og fallhøyder

(S) Monteringhöjd och fallhöjd

(UK) Assembly heights and critical fallheights

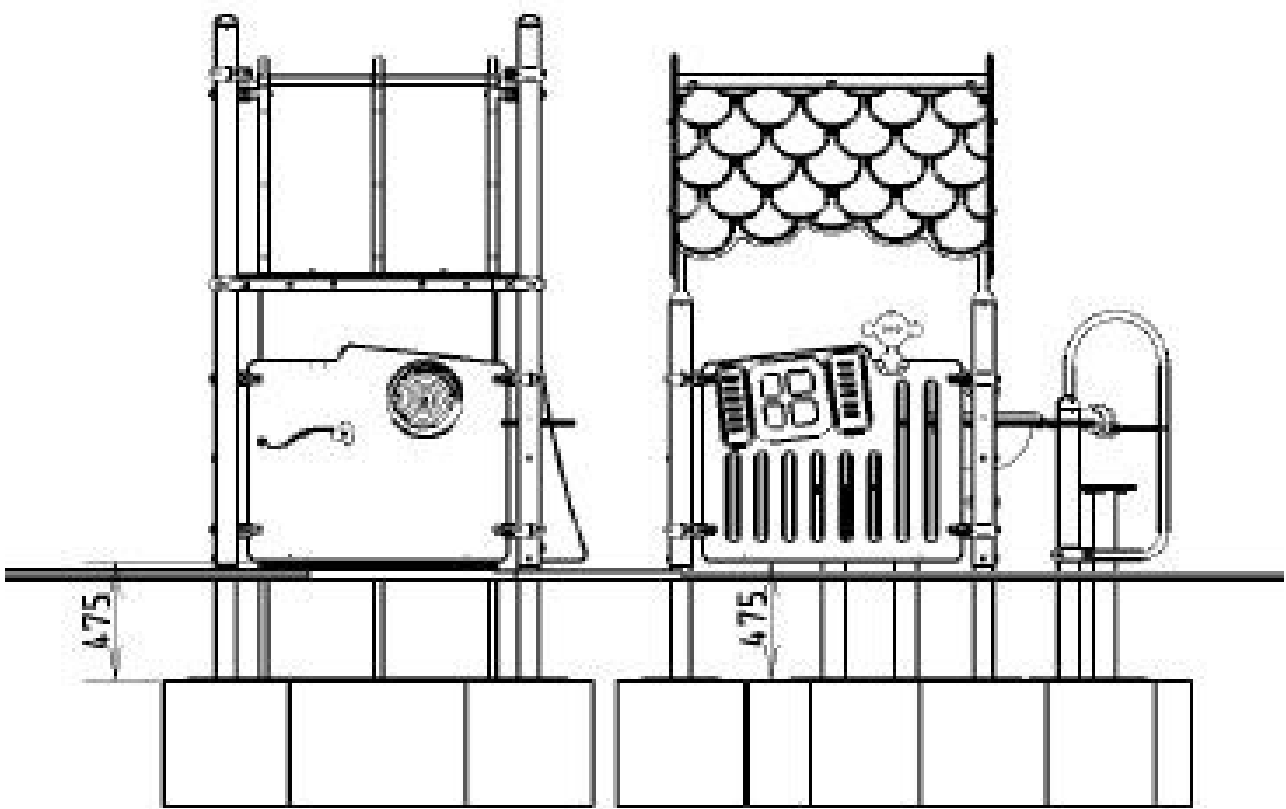
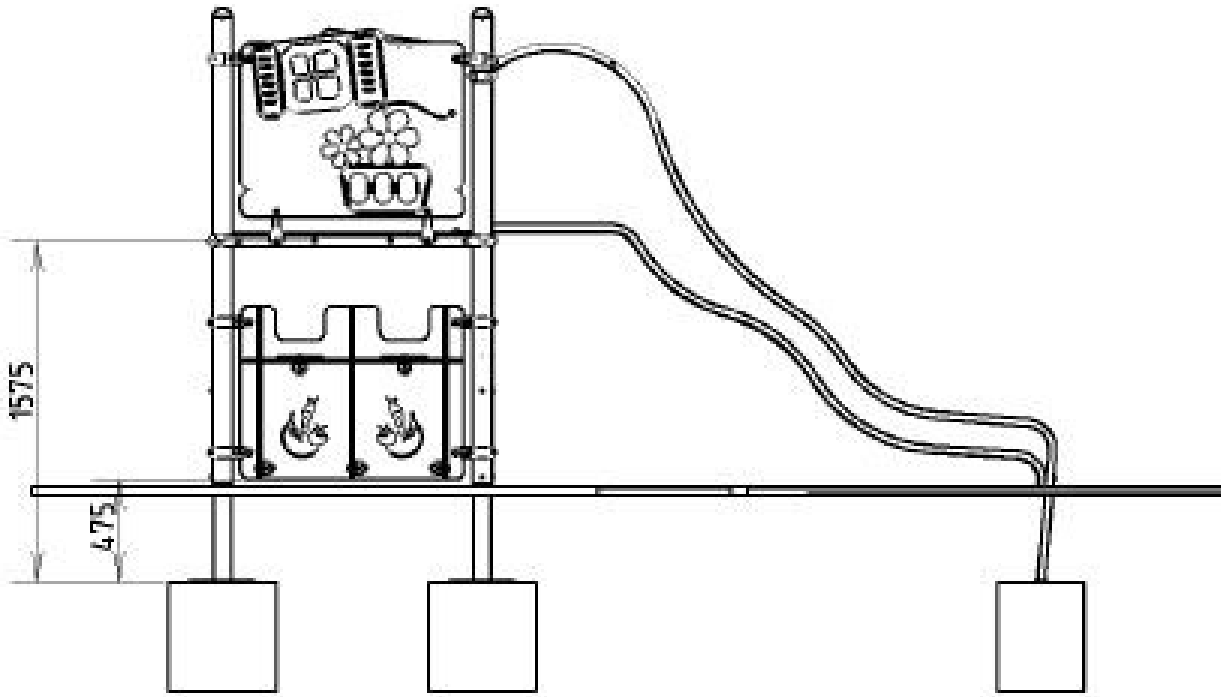

5**Fundamentering/ Concrete foundation/ Markförankring****N**

For enklere å kunne flytte eller bytte deler, støpes ikke Romantic produktene direkte i grunnen, men på følgende måte:

Fase 1:

- ❖ Støp betongblokk (50x50x50cm) som skal brukes som forankring.
- ❖ Vær oppmerksom på om stolpene skal være ift nivå 0 eller -40. Nivå 0 er tilpasset underlag med fallmatter og nivå -40 er når lekeseksjonen plasseres i et sandbasseng.
- ❖ Bruk en kikkert for å nivellere området for å få betongfundamentene riktig ift forankringstegning.

Fase 2:

- ❖ Forankringsplaten festes til betongfundamentene med forankringsbolter etter at lekeseksjonen er ferdig montert.

UK

In order to allow any future moving of or changes to the equipment, HUSSON COLLECTIVITES play equipment is not anchored directly in the concrete, but fixed to the ground as follows:

Phase 1:

- ❖ Casting on-site of concrete blocks 350 Kg/m³
- ❖ Laying out using a theodolite in accordance with the indications of the specific anchoring plan included with the instructions.

Phase 2 : (Fixing the play equipment on the concrete blocks or slabs)

- ❖ After the concrete has been left to dry for at least two weeks, the equipment can be fixed to the ground
- ❖ The upright plates are fastened onto the concrete blocks using Spit studs after the equipment has been completely assembled.

S

För att enklare kunna flytta utrustningen eller byta delar, gjuts inte Äventyr produkten direkt i marken, utan förankras på följande sätt:

Fas 1:

- ❖ Gjut betongblock (50x50x50xm) som används som markankare
- ❖ Var uppmärksam på om stolparna skall vara i nivå 0 eller -40. Vid Nivå 0 är stolparna anpassad för fallmattor och vid nivå -40 plasseras lekställningen i sand.
- ❖ Använd en kikare för att nivellera platsen för betongförankringarna korrekt enligt förankringsritningen.

Fas 2 :

- ❖ Förankringsplattan fästes till betongförankringen med förankringsbultar efter att leksektionen är färdigmonterad.

6**Klammer/ Clamps/ klämmor****N****Montering/sammestilling av klammer (D.89 clamp)**

Hver klammerdel er merket med et nummer som er preget på delen. Det er viktig at hver del blir satt sammen iht tegningene som følger.

NB Ikke bland klammerene til de ulike delene av seksjonen!

Eks. JPI-0050 –PP og JPI 0049 –PP hører sammen.

UK**Assembly/fitting the clamps (D.89 clamp)**

All clamps is fitted together by two parts with unique numbers for each part. It is essential that correct parts are fitted together according to the drawings as follows.

NB! DO NOT MIX THE CLAMPS FOR THE DIFFERENT PARTS OF THE PLAYGROUNDEQUIPMENT!

Ex. JPI-0050 –PP and JPI 0049 –PP matches

S**Montering/sammanställning av klämmor (D.89 clamp)**

Varje klammdel är märkt med ett unikt nummer. Det är viktigt att varje del sätts ihop enligt ritningen som följer.

OBS! Blanda inte ihop klämmor från olika delar av ställningen!

Ex. JPI-0050 –PP og JPI 0049 –PP hör i hop.

N

Klammer: (Mutter og bolter inkludert)

- 1.Klamme d.34
- 2.Klammer \varnothing 89 1 utgang
- 3.Klammer \varnothing 89 2 utganger 60°
- 4.Klammer \varnothing 89 2 utganger 90°
- 5.Klammer \varnothing 89 2 utganger 120°
- 6.Klammer \varnothing 89 2 utganger 150°
- 7.Klammer \varnothing 89 2 utganger 180°
- 8.Klammer \varnothing 89 3 utganger 60°
- 9.Klammer \varnothing 89 3 utganger 90°
- 10.Klammer \varnothing 89 4 utganger

UK

Clamps: (nuts and bolts included)

- 1.Clamp D.34
- 2.Clamp \varnothing 89 1 pre-equipped fastening
- 3.Clamp \varnothing 89 2 pre-equipped 90° fastenings
- 4.Clamp \varnothing 89 2 pre-equipped 180° fastenings
- 5.Clamp \varnothing 89 2 pre-equipped 60° fastenings
- 6.Clamp \varnothing 89 2 pre-equipped 120° fastenings
- 7.Clamp \varnothing 89 2 pre-equipped 150° fastenings
- 8.Clamp \varnothing 89 3 pre-equipped 60° fastenings
- 9.Clamp \varnothing 89 3 pre-equipped 90° fastenings
- 10.Clamp \varnothing 89 4 pre-equipped fastenings

S

klämmor: (Muttrar och bultar inkluderat)

- 1.klämmor D.34
- 2.klämmor \varnothing 89 1 utgång
- 3.klämmor \varnothing 89 2 utgångar 90°
- 4.klämmor \varnothing 89 2 utgångar 180°
- 5.klämmor \varnothing 89 2 utgångar 60°
- 6.klämmor \varnothing 89 2 utgångar 120°
- 7.klämmor \varnothing 89 2 utgångar 150°
- 8.klämmor \varnothing 89 3 utgångar 60°
- 9.klämmor \varnothing 89 3 utgångar 90°
- 10.klämmor \varnothing 89 4 utgångar

6 CLAMP D.34

1:2 SCREW CLAMP D.34.
JPI-0076-PP.

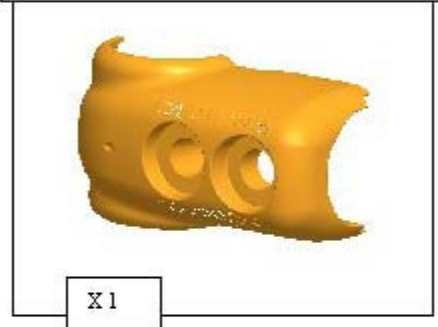

X1

1:2 NUT CLAMP D.34.
JPI-0075-PP.

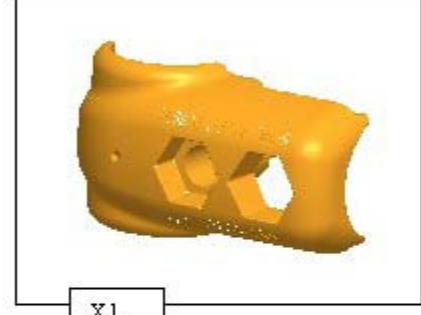

X1

LOCKWASHER D.10.
Q00337.

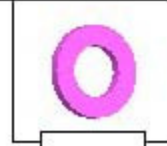

X2.

STAINLESS STEEL HM10 NUT.
Q00299.



X2

M10x55 TORX SCREW.
Q00259.



X2

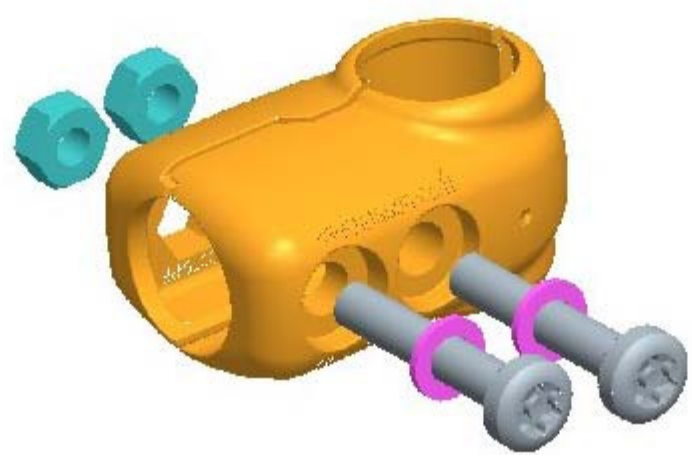

6

CLAMP D.89 1 UTGANG/CLAMP D.89 1 FASTENING/CLAMP D.89 1 UTGÅNG

1:2 . D.89 CLAMP WITH 1 FASTENING
JPI-0050-PP.

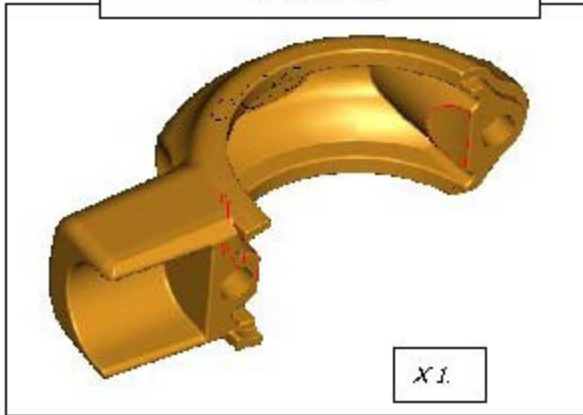

1:2 . D.89 SINGLE CLAMP.
JPI-0049-PP.

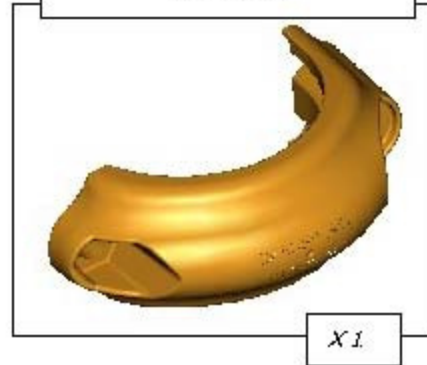

LOCKWASHER D.10.
Q00337.



X 3.

M10x55 TORX SCREW.
Q00259.



X 3.

STAINLESS STEEL HM10 NUT.
Q00299.



X 3.

D.89 CLAMP COVER.
JPI-0052-PP.



X 1.

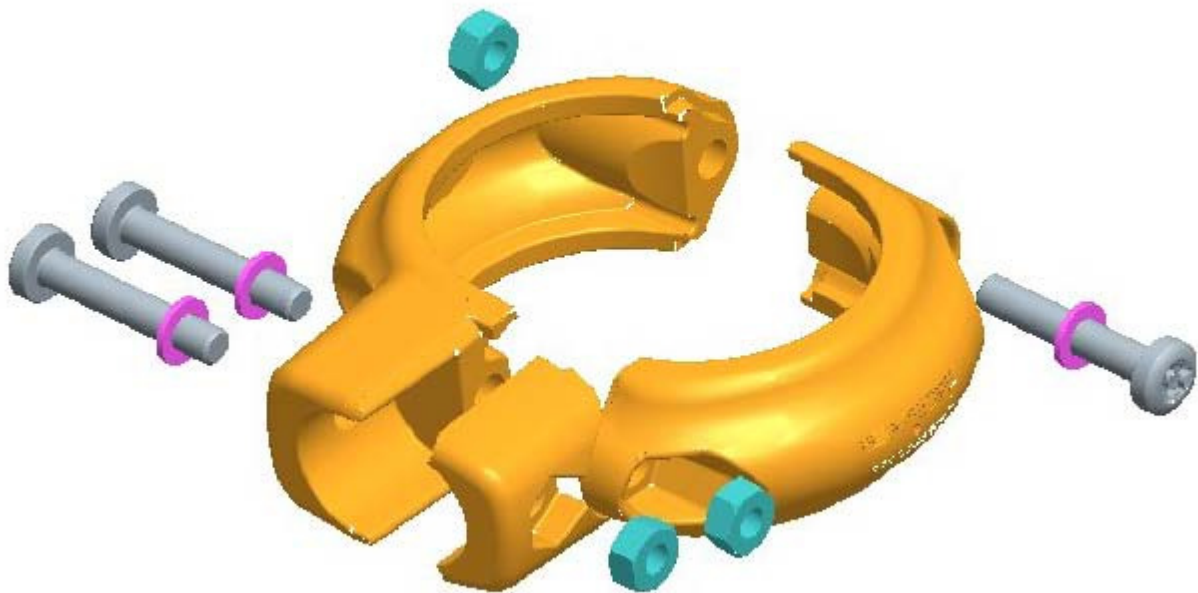

6

CLAMP D.89 2 UTGANGER 60 °/CLAMP D.89 2 FASTENING 60 °/CLAMP D.89 2 UTGÅNGAR 60 °

1:2 89 CLAMP WITH 1 FASTENING 60°
JPI-0324-PP3

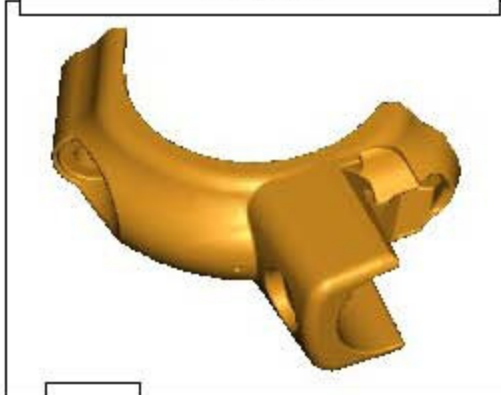

X 13

1:2 89 CLAMP WITH 1 FASTENING 3
JPI-0050-PP3

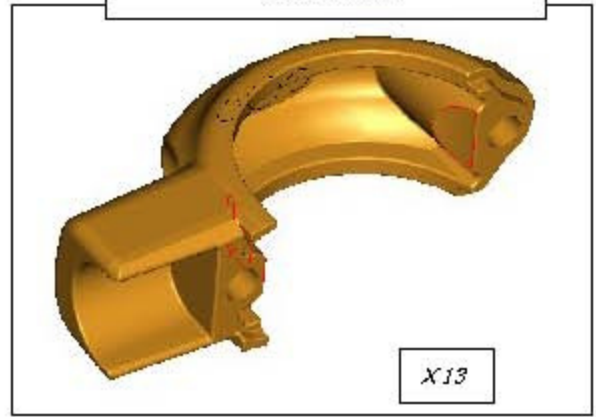

X 13

LOCKWASHER D.103
Q003 73



X 43

STAINLESS STEEL HM10 NUT 3
Q002993



X 43

M10x55 TORX SCREW 3
Q002593



X 43

D.89 CLAMP COVER 3
JPI-0052-PP3

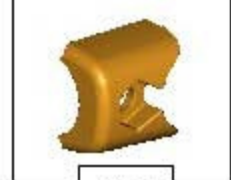

X 23

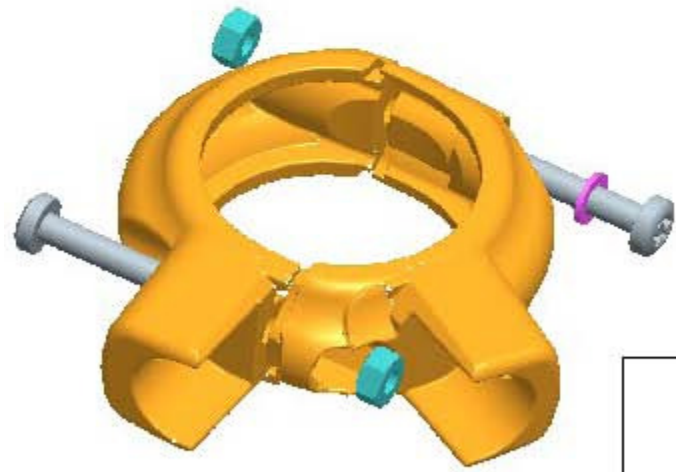

Phase 23

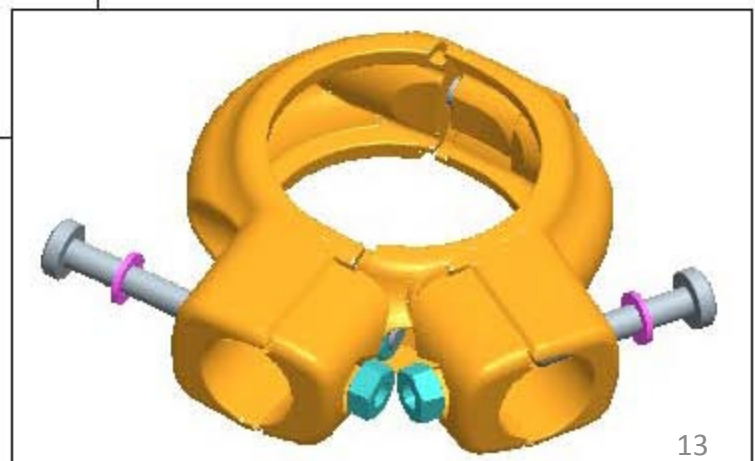

6 CLAMP D.89 2 UTGÅNGER 90 °/CLAMP D.89 2 FASTENING 90 °/CLAMP D.89 2 UTGÅNGAR 90 °

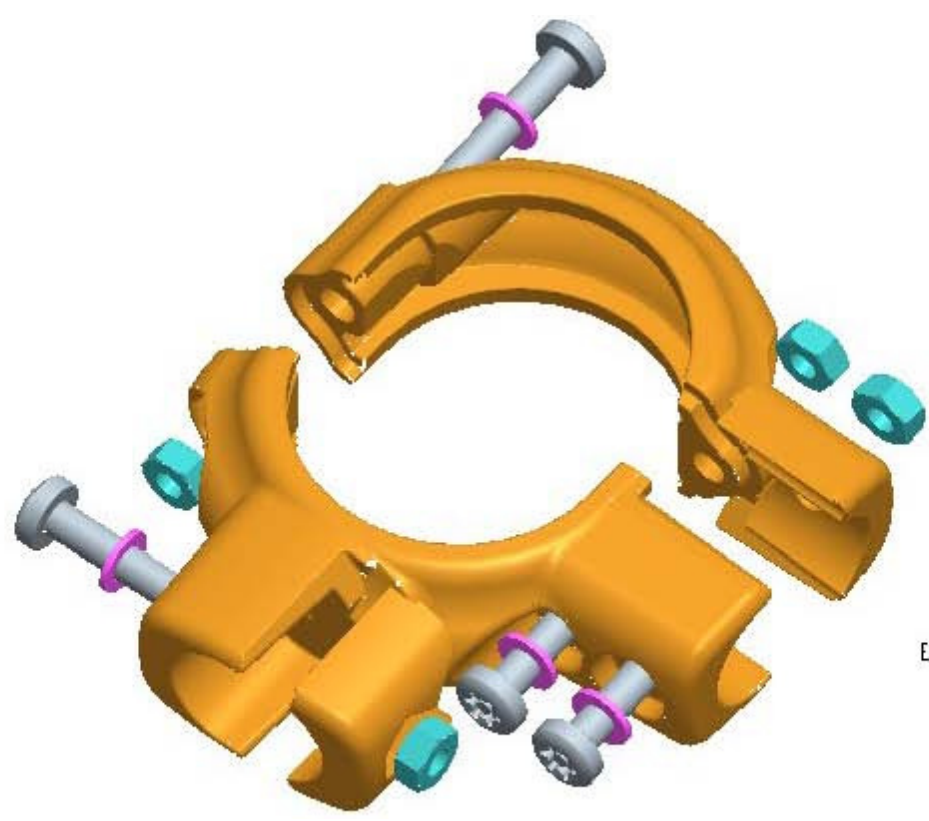
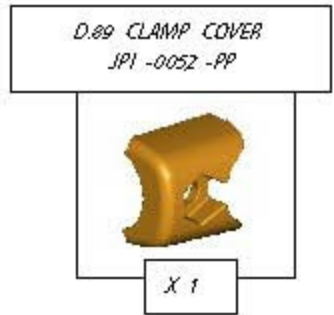
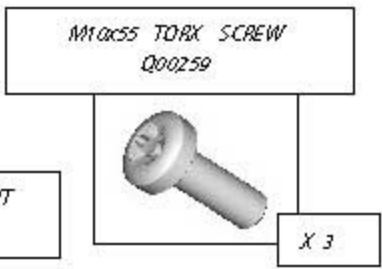
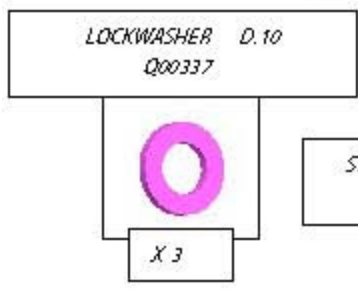
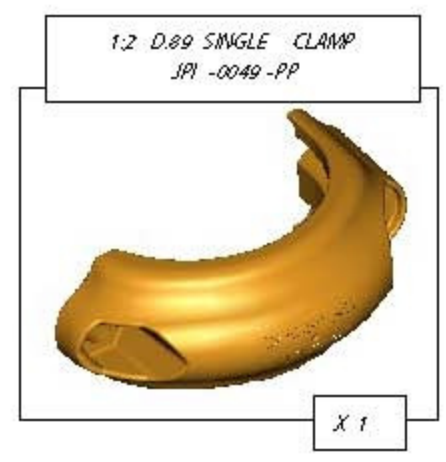
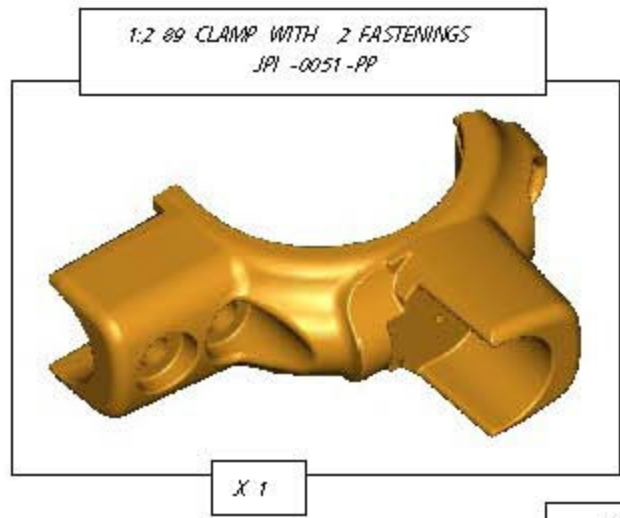

6

CLAMP D.89 2 UTGANGER 120 °/CLAMP D.89 2 FASTENINGS 120 °/CLAMP D.89 2 UTGÅNGAR 120 °

1:2 89 CLAMP WITH 1 FASTENING 60°3
JPI-0324-PP3



X 13

1:2 89 CLAMP WITH 1 FASTENING 120°3
JPI-0325-PP3

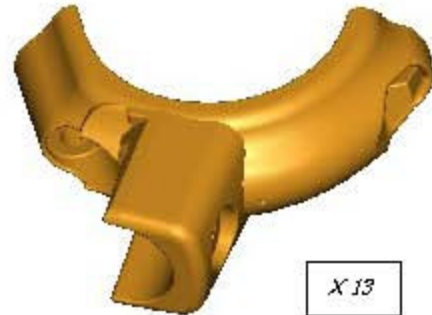

X 13

LOCKWASHER D.103
Q003 73



X 43

STAINLESS STEEL HM10 NUT3
Q002993



X 43

M10x55 TORX SCREW3
Q002593



X 43

D.89 CLAMP COVER3
JPI-0052-PP3



X 23

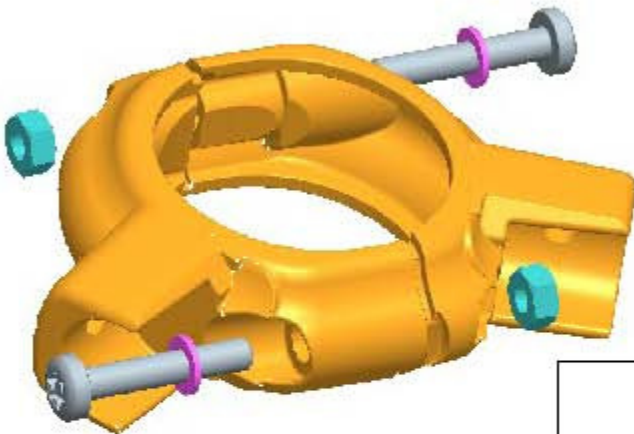

Phase 23

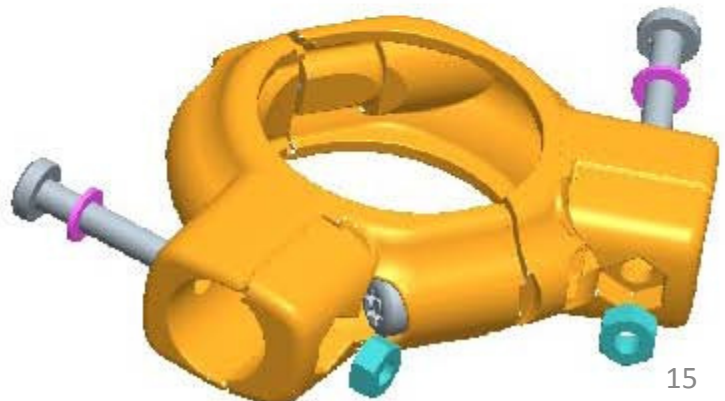

6

CLAMP D.89 2 UTGANGER 150 °/CLAMP D.89 2 FASTENING 150 °/CLAMP D.89 12 UTGÅNGAR 150 °

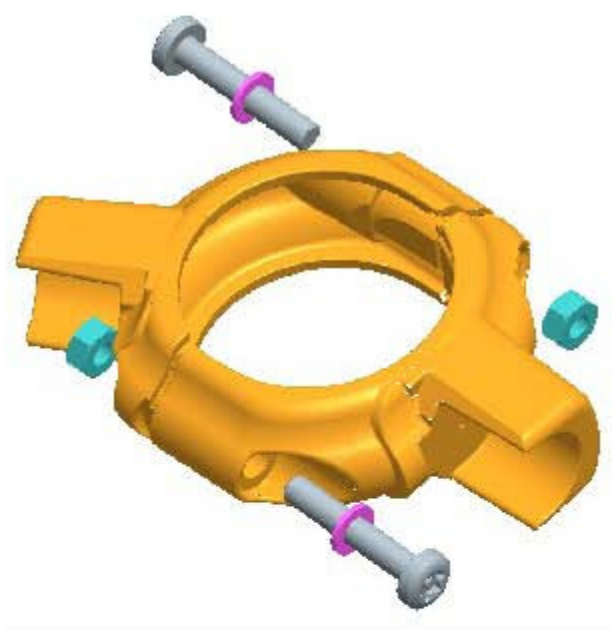
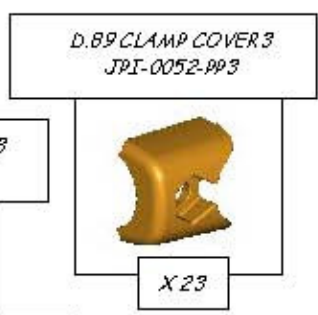
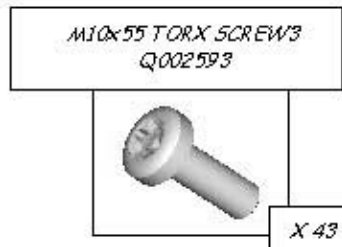
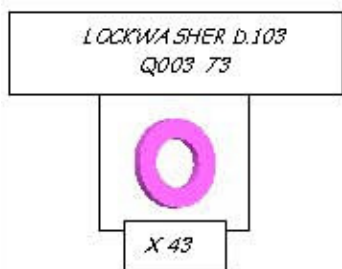
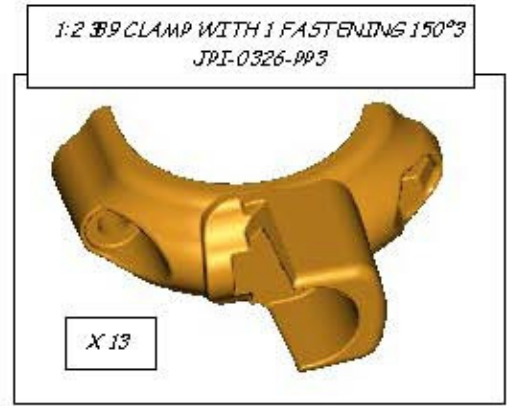
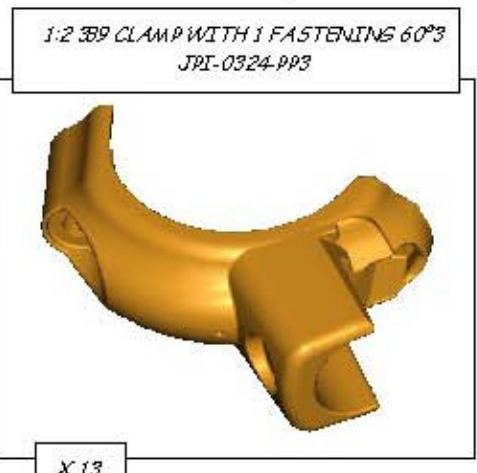

Phase 23

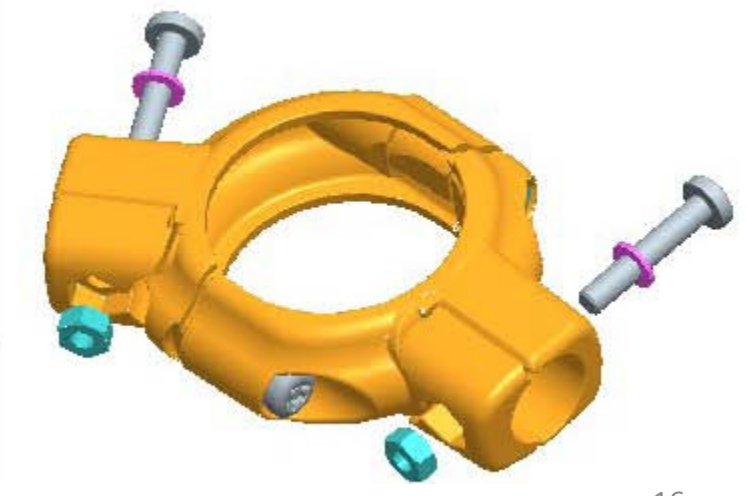

6 CLAMP D.89 2 UTGANGER 180 °/CLAMP D.89 2 FASTENING 180 °/CLAMP D.89 2 UTGÅNGAR 180 °

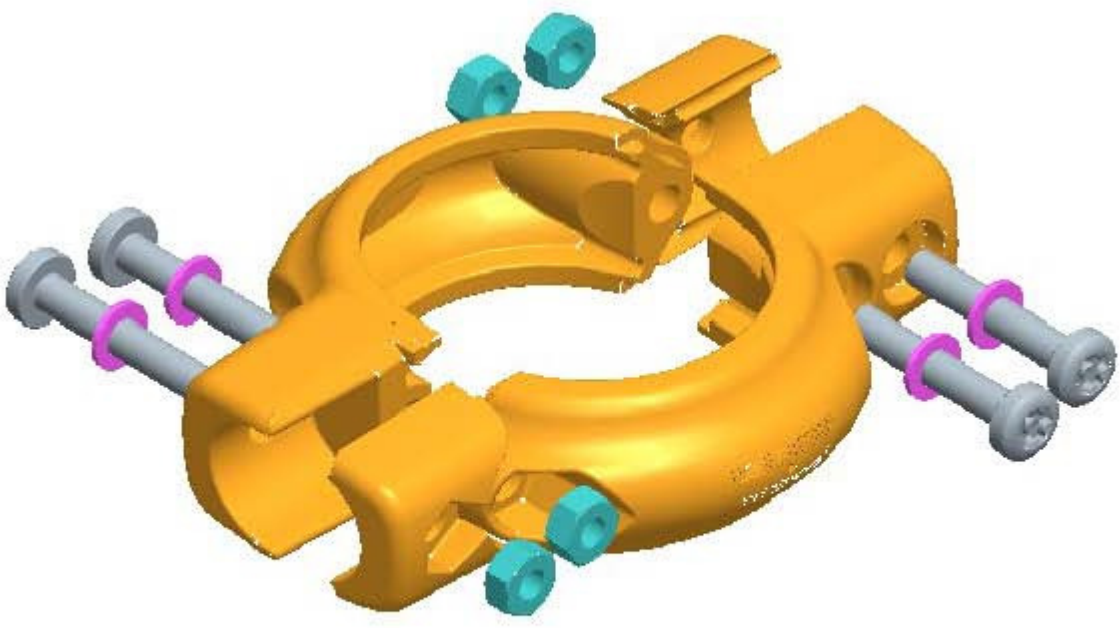
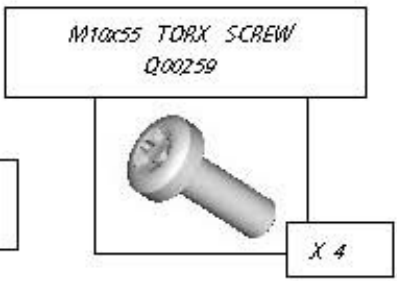
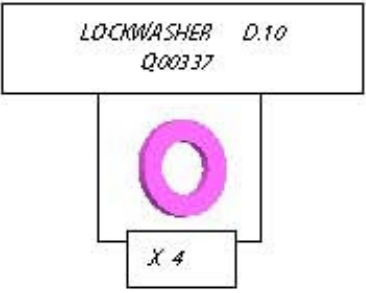
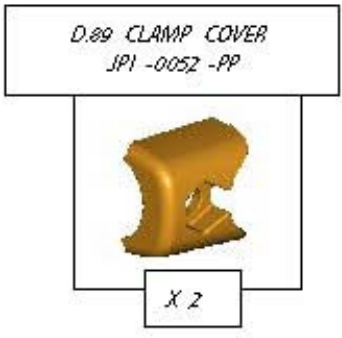
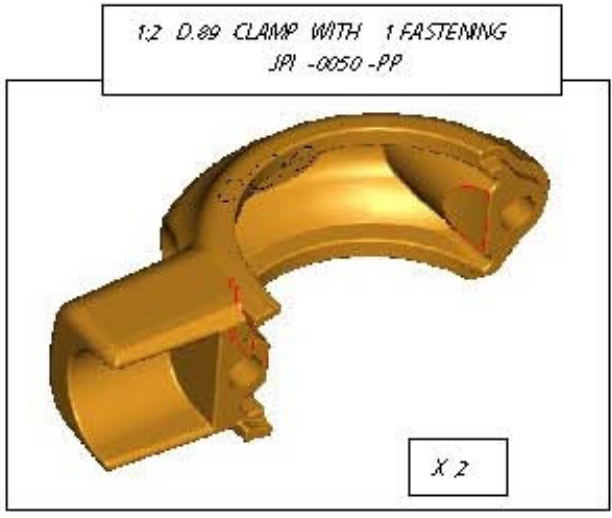

6 CLAMP D.89 3 UTGÅNGER 60 °/CLAMP D.89 3 FASTENING 60 °/CLAMP D.89 1 UTGÅNGAR 60 °

1:2 89 CLAMP WITH 1 FASTENING 60°3
JPI-0324-PP3

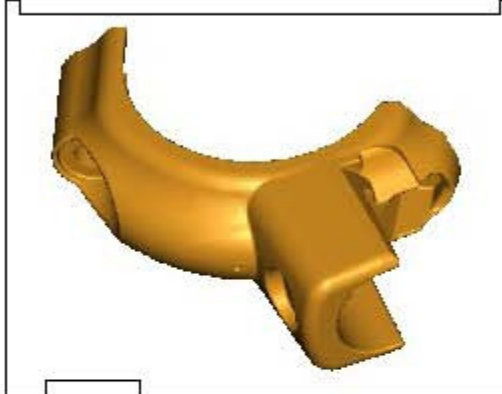

X 13

1:2 89 CLAMP WITH 2 FASTENINGS 53
JPI-0051-PP3

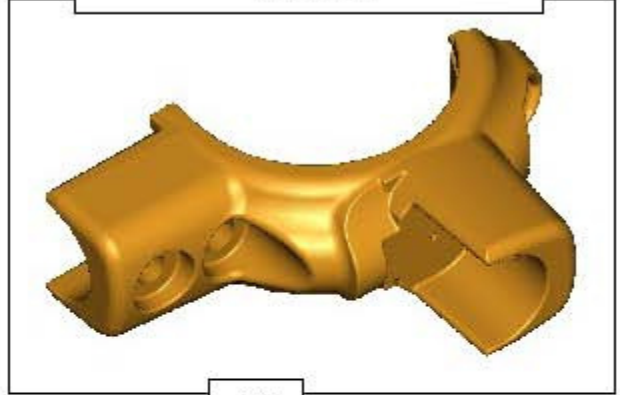

X 13

LOCKWASHER D.103
Q003 73



X 53

STAINLESS STEEL HM10 NUT3
Q002993



X 53

M10x55 TORX SCREW3
Q002593



X 53

D.89 CLAMP COVER3
JPI-0052-PP3

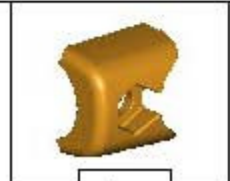

X

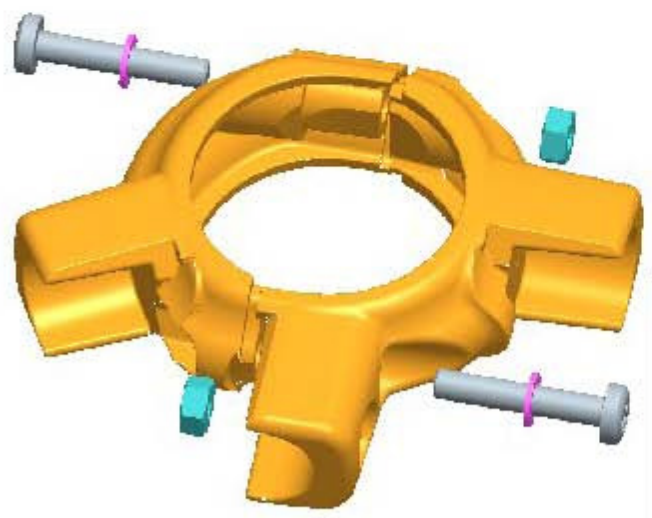

Phase 23

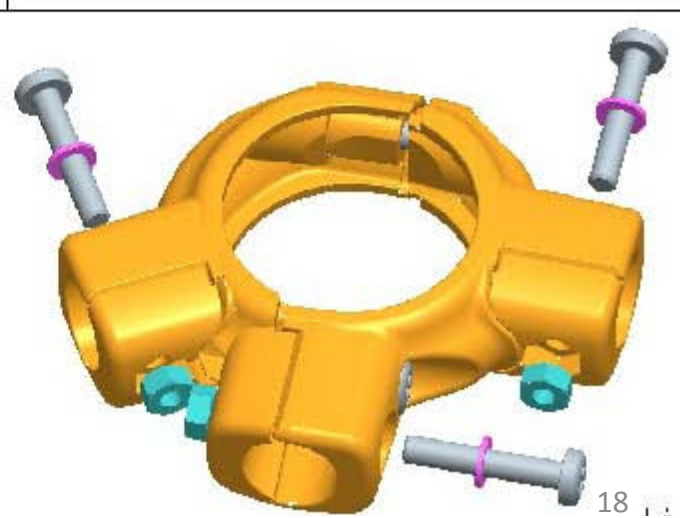

6 CLAMP D.89 3 UTGÅNGER 90 °/CLAMP D.89 3 FASTENING 90 °/CLAMP D.89 3 UTGÅNGER 90 °

1:2 89 CLAMP WITH 2 FASTENINGS.
JPI-0051-PP.

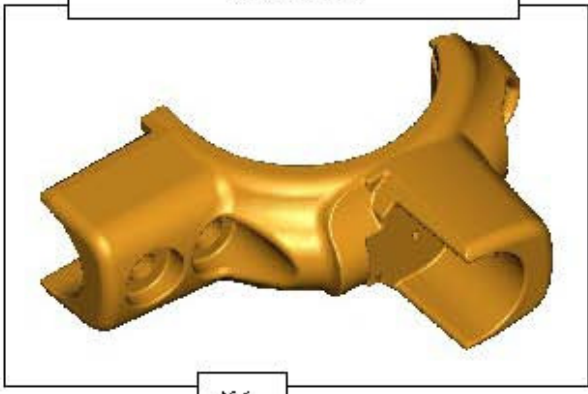

X 1.

1:2 D.89 CLAMP WITH 1 FASTENING.
JPI-0050-PP.

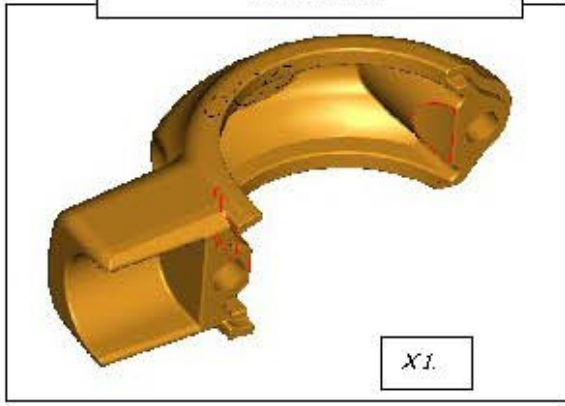

X 1.

LOCKWASHER D.10.
Q00337.

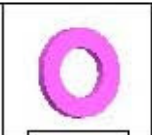

X 5.

M10x55 TORX SCREW.
Q00259.



X 5.

STAINLESS STEEL HM10 NUT.
Q00299.

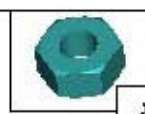

X 5.

D.89 CLAMP COVER.
JPI-0052-PP.

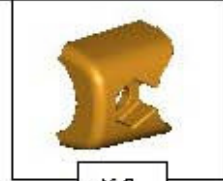

X 3.

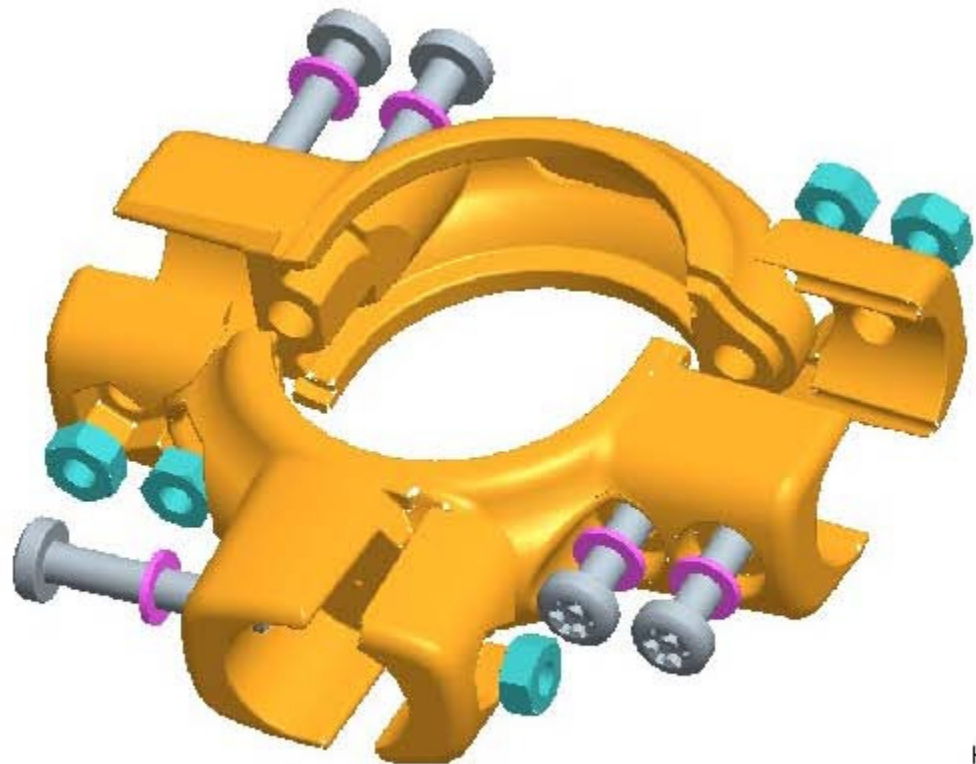

6

CLAMP D.89 4 UTGANGER/CLAMP D.89 4 FASTENING/CLAMP D.89 4 UTGÅNGAR

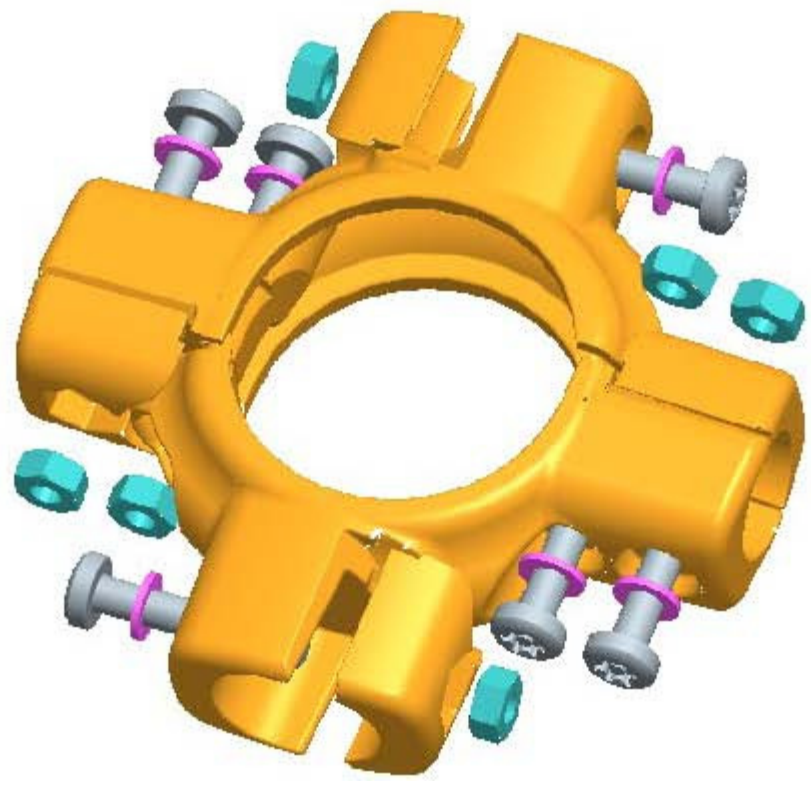
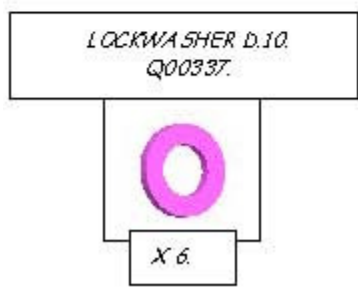
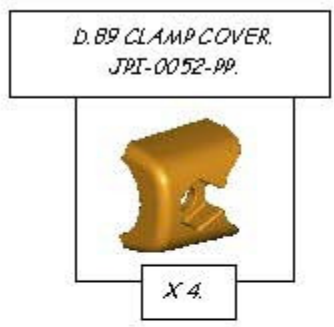
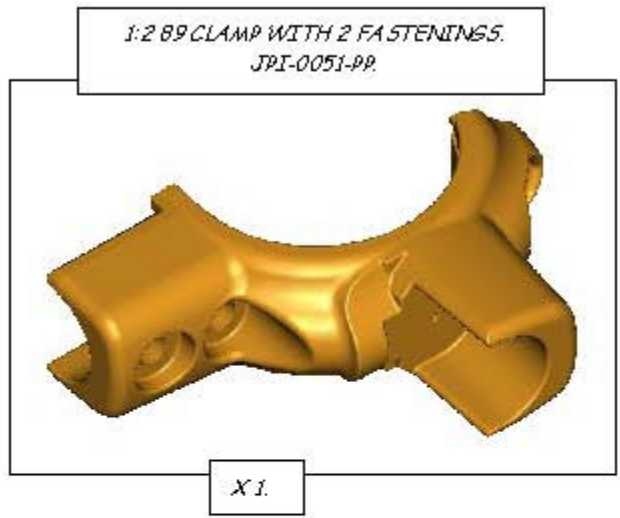

<p>7</p>	<p>MONTERING I KRONOLOGISK REKKEFØLGE ASSEMBLY OPERATIONS IN CHRONOLOGICAL ORDER MONTERING I KRONOLOGISK ORDNING</p>
<p>(N)</p>	<ol style="list-style-type: none"> 1 Montér forankringsplatene til stolpene. 2 Montér gulv. 3 Montér tak. 4. Montér bru 5 Montér vegger. 6 Montér benk/bord 7 Montér stige 8 Montér brannmannstang. 9 Montér klatrenett 10 Montér sklie. <p>Dersom lekeseksjonen består av flere tårn, gjenta monteringsrekkefølgen for hvert tårn og sett taket i forhold til vær og vindforhold</p>
<p>(UK)</p>	<ol style="list-style-type: none"> 1 Pre-assembly of the uprights. 2 Platform assembly. 3 Roof assembly. 4 Bridge assembly 5 Side panel assembly. 6 Bench/table assembly 7 Ladder assembly 8 Fireman's pole assembly. 9 Climbing net assembly. 10 HPL slide assembly. <p>In the case of a configuration with several Towers, repeat the operations above for each of the towers, taking care to position the roof correctly in relation to the weather conditions.</p>
<p>(S)</p>	<ol style="list-style-type: none"> 1 Montera förankringsplattorna till stolparna. 2 Montera golv. 3 Montera tak. 4 Montera bron 5 Montera väggar. 6 Montera bänk/bord 7 Montera stege 8 Montera brandmanstång. 9 Montera klätternät. 10 Montera HPL rutschkana. <p>Om lekesektionen har flera torn, upprepa monteringsordningen för varje torn och placera taket i förhållande till väder och vind</p>

7 Montering av lekeapparatet / Assembly instructions / Montering av lekredskapet

(N) På de neste sidene vises monteringsanvisning for Romantic serien i kronologisk rekkefølge basert på eksempelprodukt. Monteringsrekkefølgen gjelder for alle produktene i Romantic-serien

(UK) The pages that follow show the assembly operations on a Romantic tower in chronological order, based on the example of the following configuration

(S) På de följande sidorna visas monteringsanvisning för Äventyrserien i kronologisk ordning baserad på exempelprodukter. Monteringsordningen gäller alla produkten i Äventyrserien



7

Montering stolper/ Assembly instructions posts/ Montering av stolpar

LIST OF PARTS:

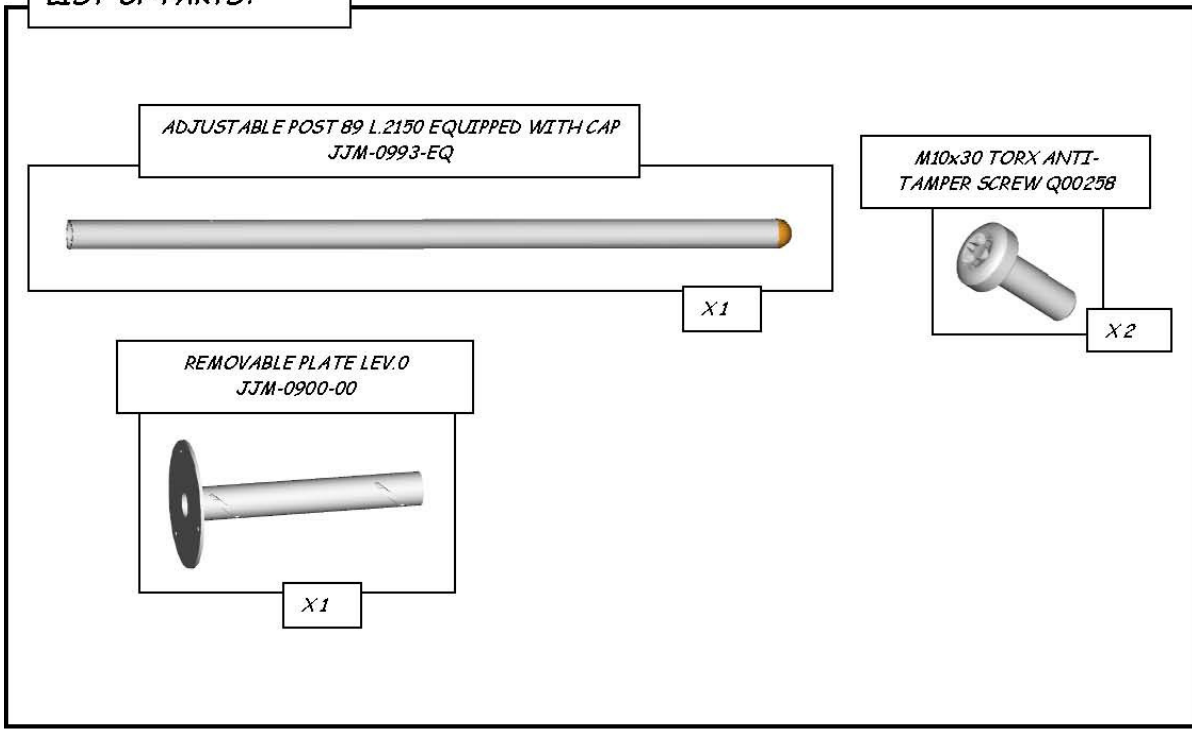

(N)

FORANKRINGSPLATER FOR STOLPER

-Fest den justerbare forankringsplaten til stolpene (2 torx screws M10x30mm)

(UK)

PRE-ASSEMBLY OF UPRIGHTS

-Fit the adjustable anchoring plate on the pre-equipped upright (2 torx screws M10x30mm)

(S)

FÖRANKRINGSPLATTOR FÖR STOLPAR

- Fäst den justerbara förankringsplattan till stolparna (2 torx screws M10x30mm)



7

Montering golv/ Assembly instructions floor/ Montering golv

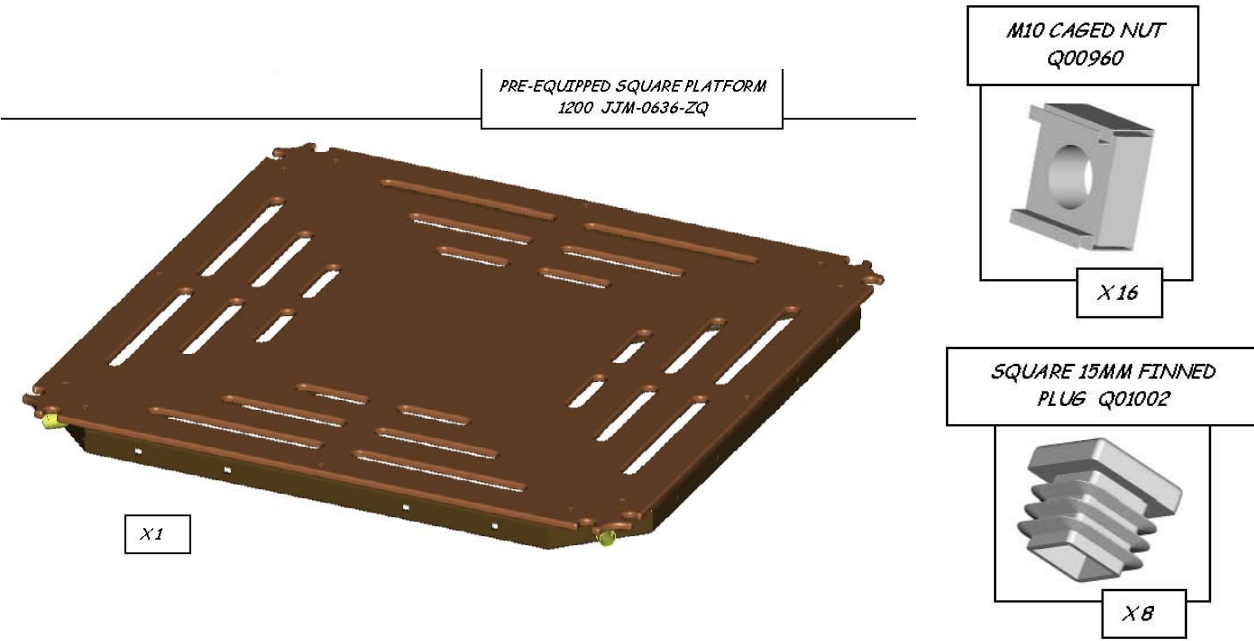

N

MONTERING GULV

- Liggende på bakken, monter gulvet til 2 av stolpene. Legg stolpene slik at klammene er i riktig posisjon for å montere fast gulvet.

UK

PLATFORM ASSEMBLY

-On the ground, assemble the platform and 2 uprights. Ensure the uprights are correctly positioned for the fitting of the roof

S

MONTERING GOLV

- Liggande på marken, montera golvet till 2 av stolparna. Stolparna måste vara i korrekt position för at montera fast golvet.

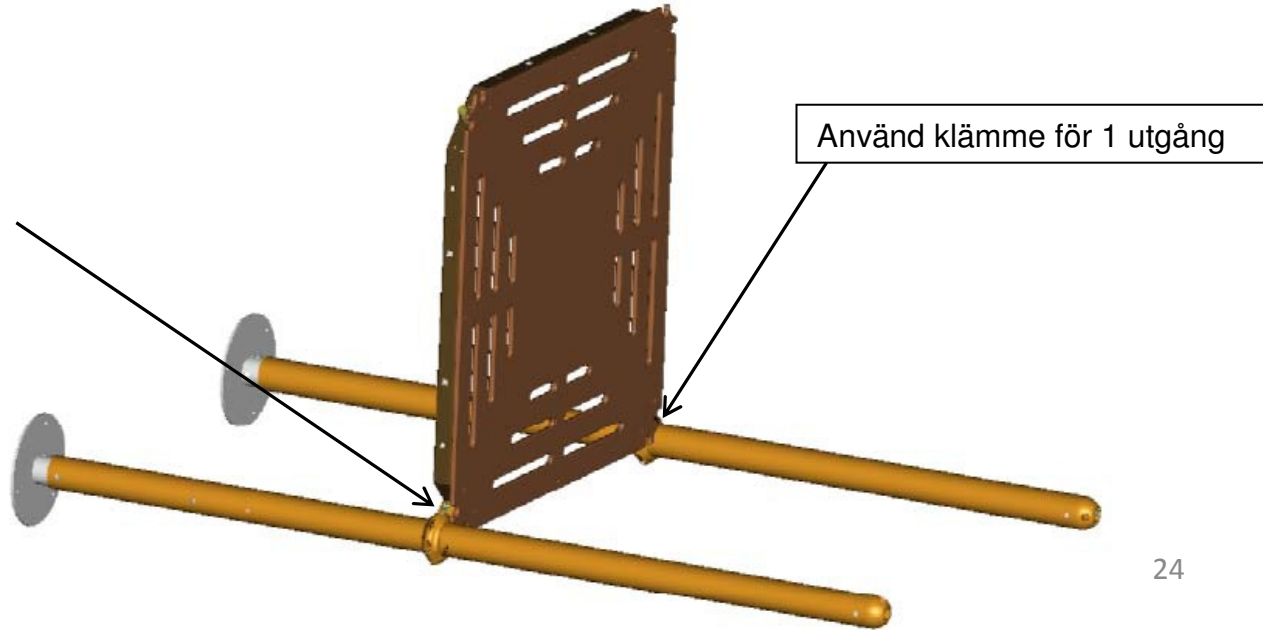

7 Montering gulv/ Assembly instructions floor/ Montering golv

(N) -Sett opp de monterte stolpene og gulvet og monter de resterende 2 stolpene
Fest gulvet til stolpene som vist i tegning
(4 stk D.89 clamps med 1 uttak)

(UK) -Place the tower in the upright position and assemble the 2 remaining uprights
Fix the floor to the posts
(4 x D.89 clamps single)

(S) -Placera de monterade stolparna och golvet lodrätt och montera sedan de 2 sista stolparna
Fäst golvet till stolparna i visad ritning
(4 st D.89 clamps med 1 utgång)

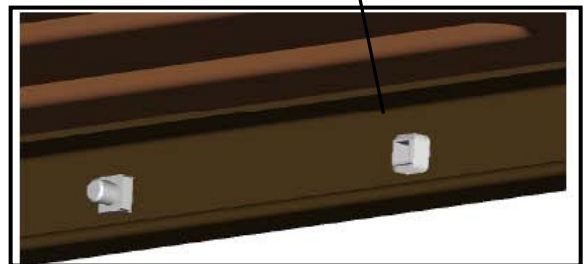
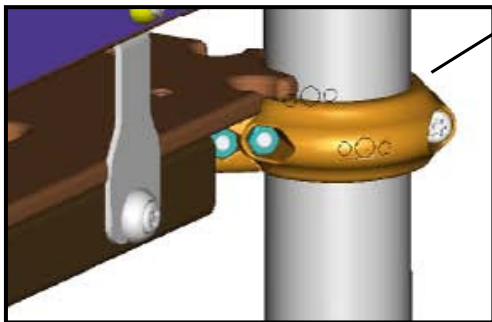

(N) Fest firkantet (M10 cage nuts) i alle hull som benyttes til å feste andre komponenter (vegger, broer, etc...)
Tett alle gjenværende hull (15 mm pluggar)

(UK) Fit the square M10 cage nuts in all the square cutouts intended to receive the components (side panels, bridges, etc...)
Block all the remaining square cutouts (square 15 mm finned plugs)

(S) Fäst (fyrkantig M10 cage nuts) i alla de förbörade hål som används till fästen av andra komponenter (väggar, broar, etc...)
Fyll i alla andra hål med 15 mm pluggar

7 Montering av golv/ Assembly instructions floor / Montering golv

- (N) SAMMENFESTING MELLOM FIRKANTET OG TREKANTET GULV
- Monter firkantgulvet med 4 klammer m/1 utgang D-89 ref Jpi-0081-ki
 - Ta bort 2 rør D.34 l 300 fra undersiden av gulvet, men husk å sette inn bolter for å unngå klemmfare for fingre
 - Fest trekantgulvet til firkantgulvet (Torx screw M10x30 + alu torx washers + cage nut M10)
 - Fest trekantgulvet til motsatte stolpe som har 1 klamme med 1 utgang D.89 ref. Jpi-0081-ki

- (UK) CONNECTION BETWEEN SQUARE AND TRIANGULAR FLOOR
- Place the square floor with 4 clamps (1 fixing) D-89 ref Jpi-0081-ki
 - Put the 2 tubes D.34 lg 300 away from the triangular floor, but put in place of the tubes the bolting to avoid any fingers entrapment
 - Assembly the triangular floor with the sqare floor(Torx Screw M10x30 + alu torx washers + cage nut M10)
 - Put the triangular floor on the opposite poste with 1 clamp (1 fixing) D.89 ref. Jpi-0081-ki

- (S) SAMMANFÄSTNING MELLAN FYRKANTIGT OCH TREKANTIGT GOLV
- Montera fyrkantgolvet med 4 klämmor m/1 utgång D-89 ref Jpi-0081-ki
 - Ta bort 2 rör D.34 l 300 från undersidan av golvet, men kom ihåg att sätta i bultar för att undvika klämrisk för fingrar
 - Fäst trekantgolvet till fyrkantgolvet (Torx screw M10x30 + alu torx washers + cage nut M10)
 - Fäst trekantgolvet till motsatta stolpar som har 1 klämma med 1 utgång D.89 ref. Jpi-0081-ki

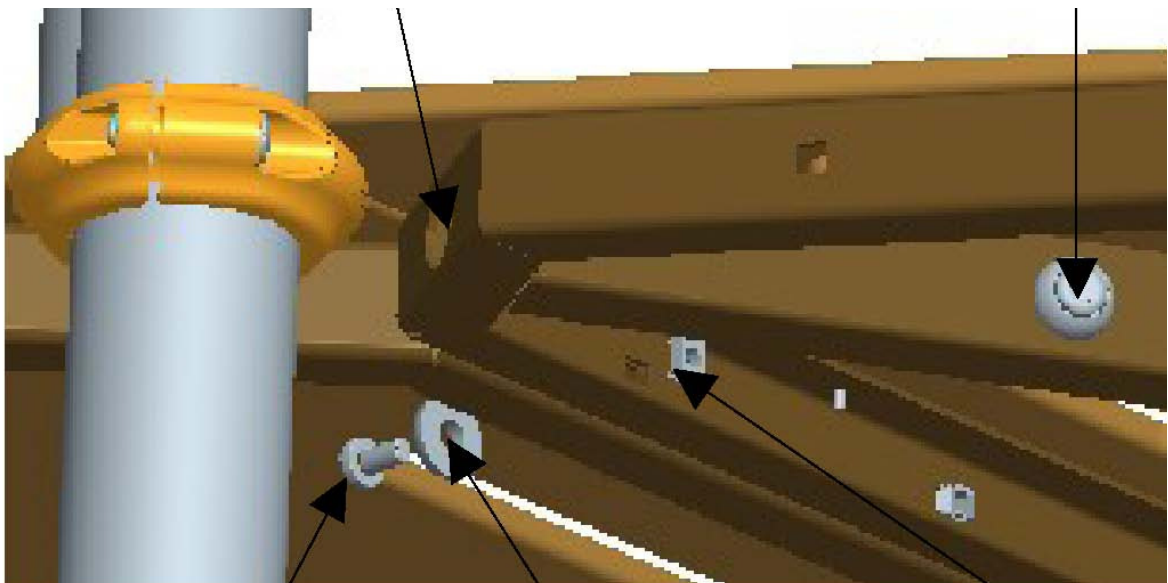

7

Montering gulv/ Assembly instructions floor/ Monterings gulv

N

PRE-EQUIPPED TRIANGULAR
PLATFORM JJM-0637-ZQ

SQUARE 15MM FINNED
PLUS Q01002

UK



X 6

S



M10 CAGED NUT
Q00960

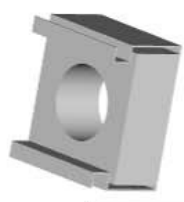

X 12

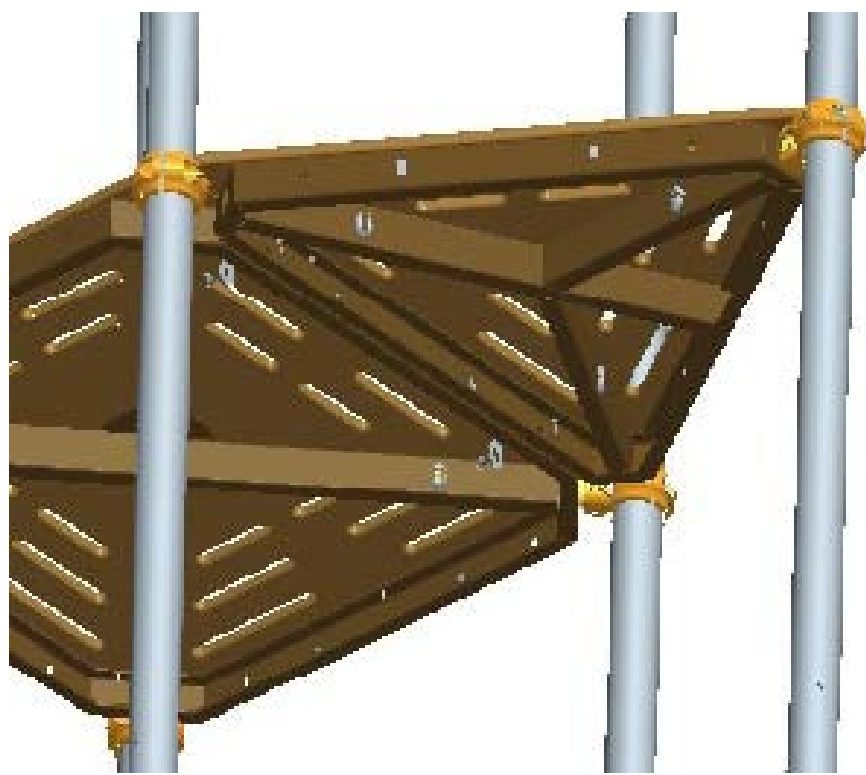

7

Montering tak/ Assembly instructions roof/ Montering tak

LIST OF PARTS:

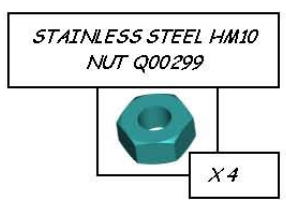
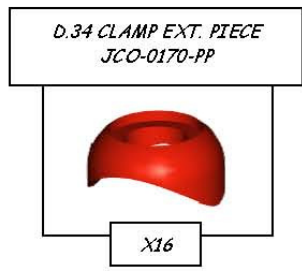
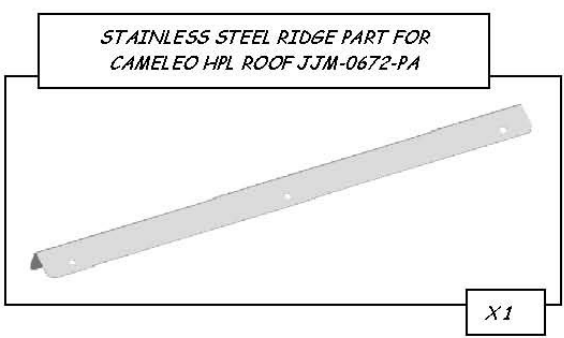
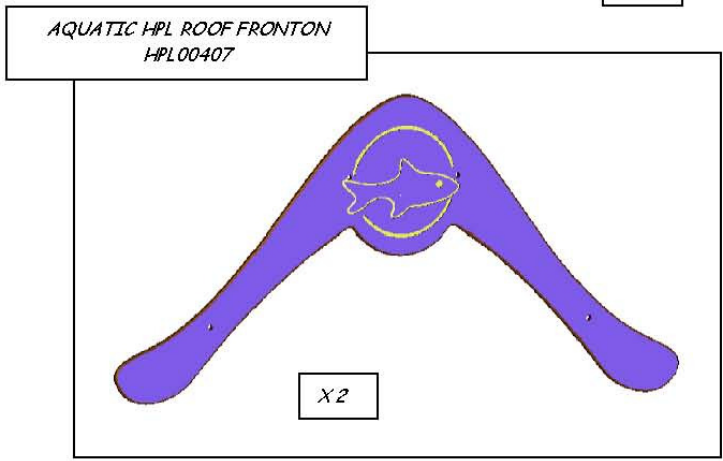
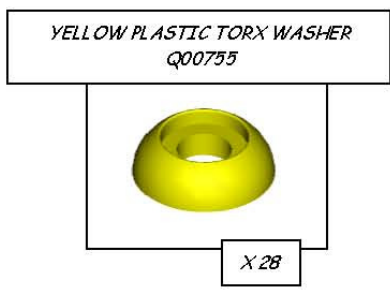
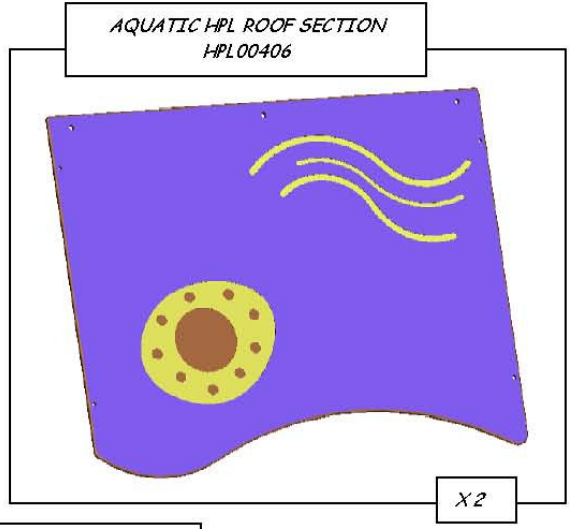
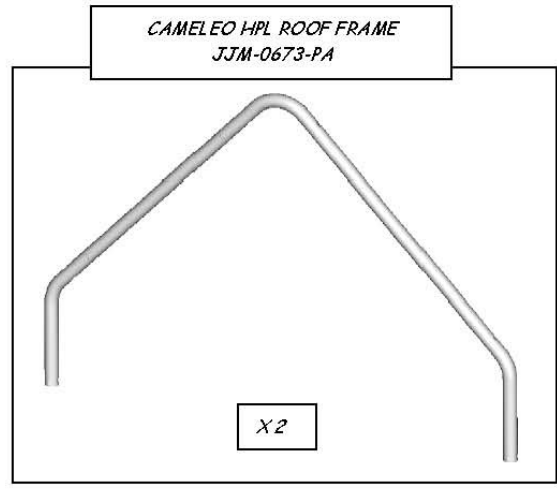

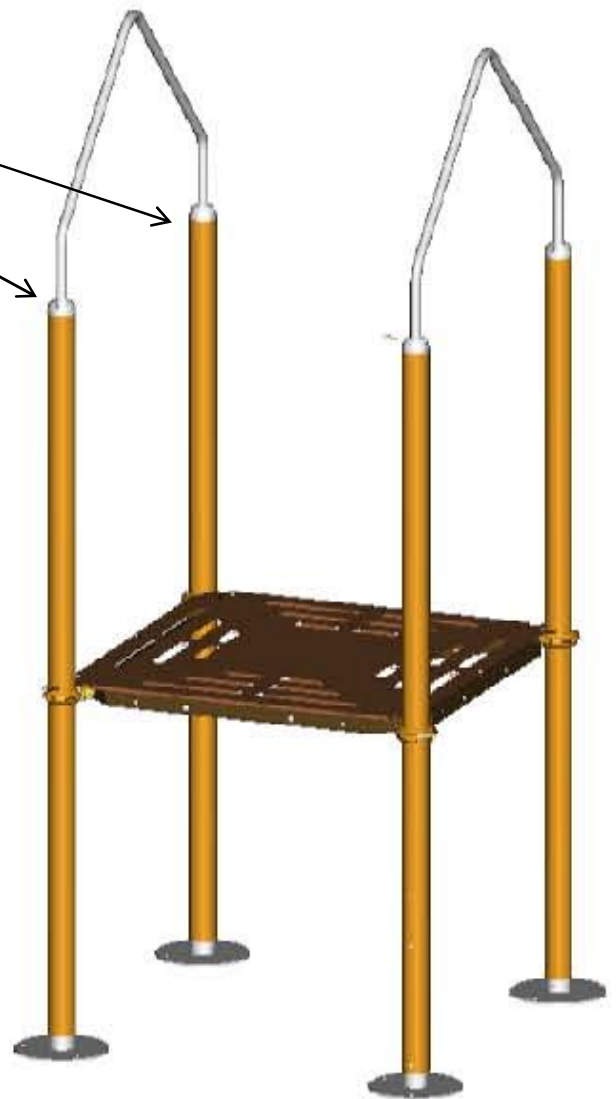
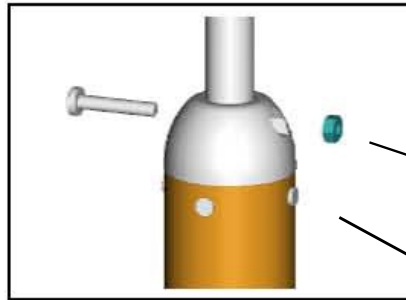
7**Montering tak/ Assembly instructions roof/ Montering tak**

- (N) Fest takrammen til toppen av stolpene med (M10 + 55 screws + M10 nuts) i riktig posisjon, men skru ikke muttrene til!
- (UK) Fit the HPL roof framing onto the posts with reducing adapters, taking care to place the roof in the right direction (M10 + 55 screws + M10 nuts) BUT DO NOT TIGHTEN
- (S) Fäst takramen till toppen av stolparna med (M10 + 55 screws + M10 nuts) i korrekt position, men skruva inte fast!

- (N) Fest HPL takplatene til rammen (M10x55 screws + aluminum torx washers + torx cap nuts D.34 clamp ext. pieces),men ikke dra til!
- (UK) Fit the HPL roof sections , but do not tighten! (M10x20 screws + aluminum torx washers + torx cap nuts + D.34 clamp ext. pieces
- (S) Fäst HPL takplattorna till ramen (M10x55 screws + aluminum torx washers + torx cap nuts D.34 clamp ext. pieces), men skruva inte fast!

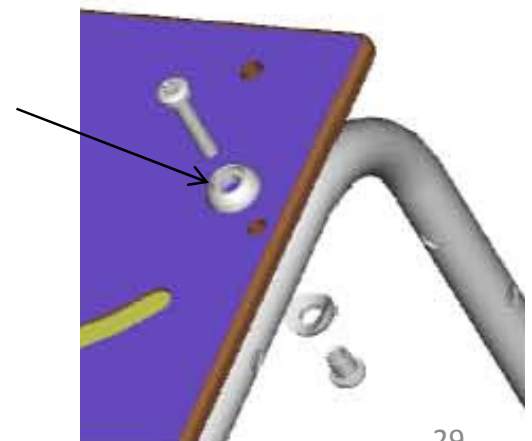

7

Montering tak/ Assembly instructions roof/ Montering tak

(N) Fest HPL mønen til taket, men ikke dra til!
(M10x20 screws + aluminum torx washers + torx cap nuts)

(UK) Fit the HPL roof sections , but do not tighten!
(M10x20 screws + aluminum torx washers + torx cap nuts

(S) Fäst HPL toppdelen till taket, men skruva inte åt muttrarna!
(M10x20 screws + aluminum torx washers + torx cap nuts)

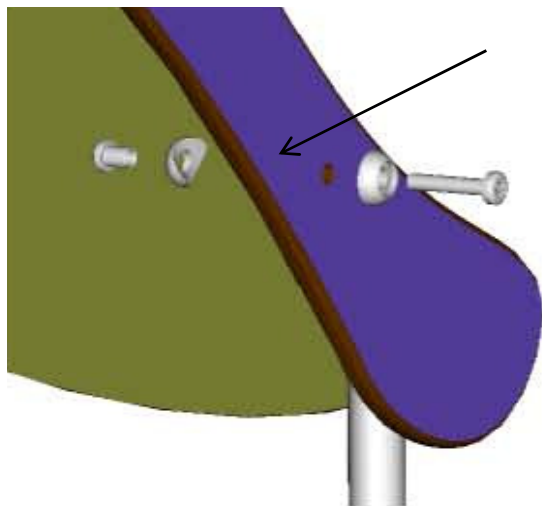
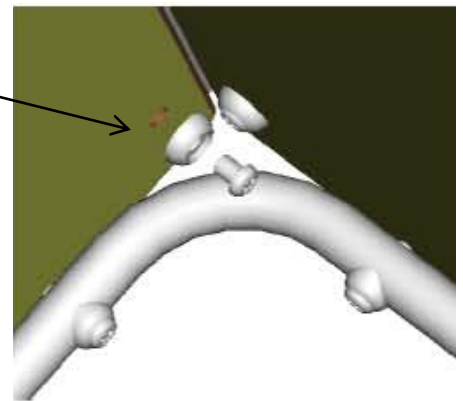
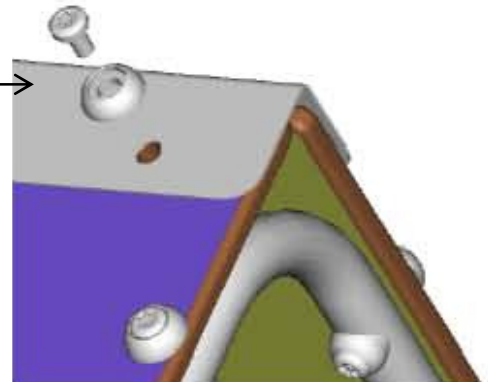

(N) Fest taksidene, men ikke dra til!
(M10x55 screws + aluminum torx washers + torx cap nuts + D.34 clamp ext. Pieces)

(UK) Fest taksiden, men ikke dra til!
(M10x55 screws + aluminum torx washers + torx cap nuts + D.34 clamp ext. Pieces)

(S) Fäst taksidan, men skruva inte åt muttrarna!
(M10x55 screws + aluminum torx washers + torx cap nuts + D.34 clamp ext. Pieces)

(N) Juster det monterte taket og dra så til alle bolter

(UK) Adjust til whole roof assembly, then tighten all the bolts

(S) Justera det monterade taket och dra åt alla bultar

7

Montering bru m/HPL rekkverk/ Assembly instructions bridge w/HPL railing
/ Montering bro med HPL racke

LIST OF PARTS:

METAL BRIDGE RAILING - HPL SLIDE ENTR.
JJM-0909-6P

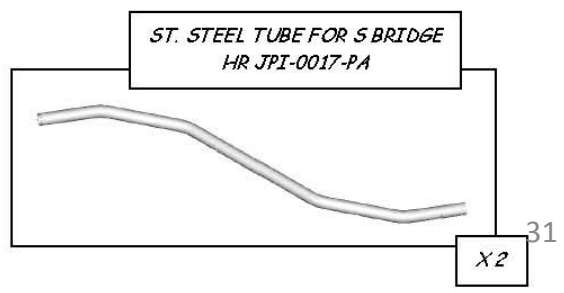
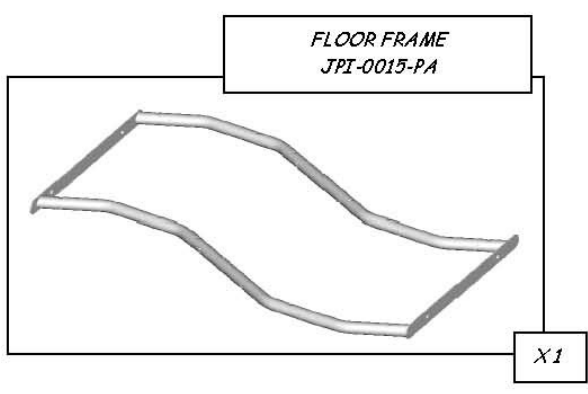
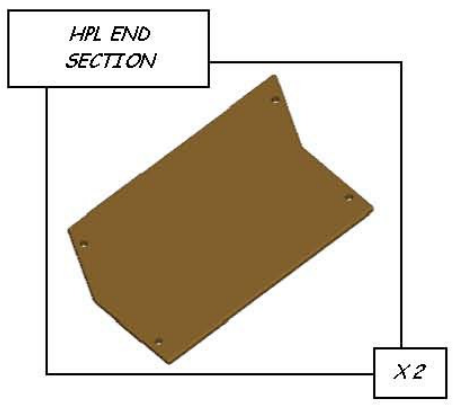
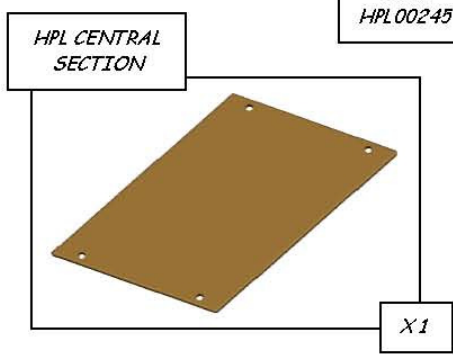
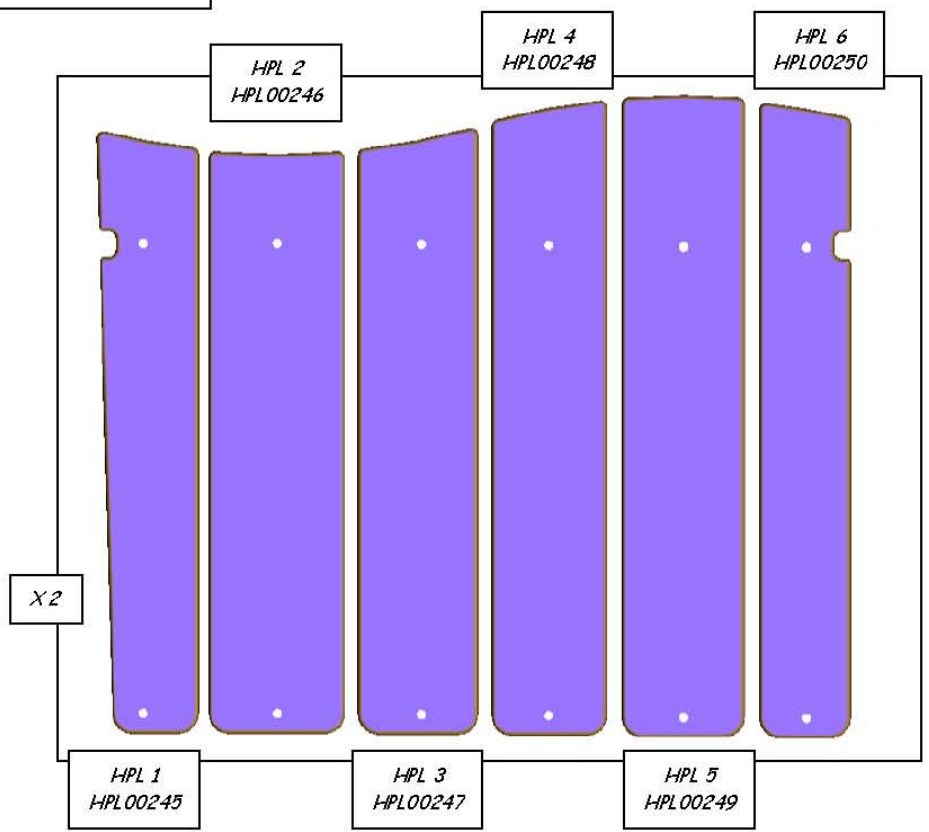
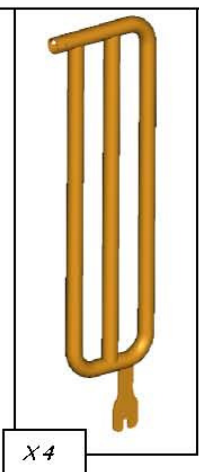

7

**Montering bru m/HPL rekkverk/ Assembly instructions bridge w/HPL railing
/ Montering bro med HPL räcke**

LIST OF PARTS:

PRE-EQUIPPED Ø33.7 CLAMP
JPI-0076-KI



X 4

STAINLESS STEEL M10 TORX ANTI-TAMPER CAP NUT Q00261



X 24

M10x55 TORX ANTI-TAMPER SCREW Q00259



X 28

M10x30 TORX ANTI-TAMPER SCREW Q00258



X 4

RED PLASTIC TORX WASHER Q00991



X 24

D.34 CLAMP EXT. PIECE JCO-0170-PP



X 36

ALUMINIUM TORX WASHER Q00753



X 8

M10x45 TORX ANTI-TAMPER SCREW Q01044



X 12

HPL SHIM TH. 25 FOR S BRIDGE HPL00381



X 2

ST. STEEL M10 INSERT Ø25 HT=14MM



X 12

7 Montering bru m/HPL rekkverk/ Assembly instructions bridge w/HPL railing
/ Montering bro med HPL räcke

NB: MONTER "S" PÅ BROEN I DEN REKKEFØLGEN SOM VISES!

**NB: YOU MUST ASSEMBLY THE "S" OF THE BRIDGE IN THE ORDER INDICATED
IN THE DRAWINGS**

NB: MONTER "S" PÅ BROEN I DEN REKKEFØLGEN SOM VISES!

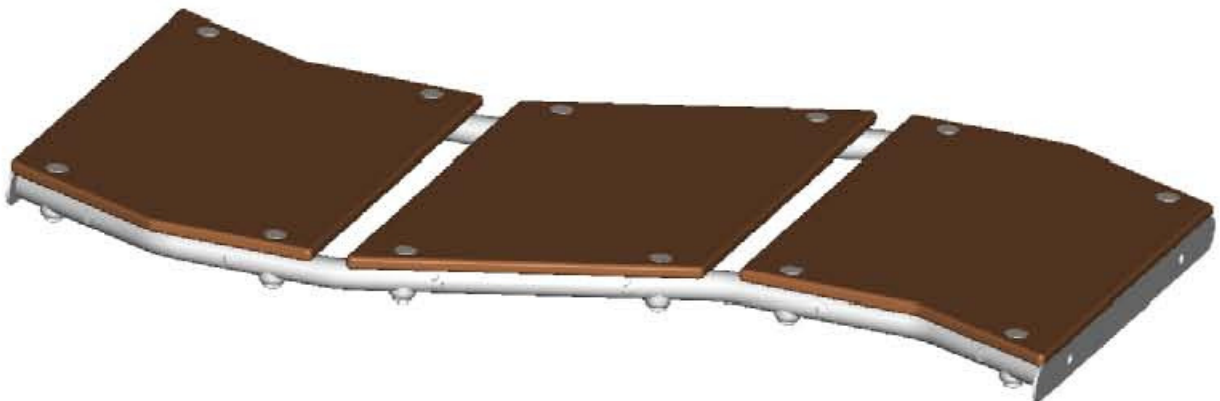

1. Fest HPL gulvplatene til metallrammen
(M10x55 screws + D.34 clamp ext. Pieces + M10
inserts)

1. Mount the HPL floor panels onto the metal frame
(M10x55 screws + D.34 clamp ext. Pieces + M10 inserts)

1. Fäst HPL golvplattorna till metallramen
(M10x55 screws + D.34 clamp ext. Pieces + M10 inserts)

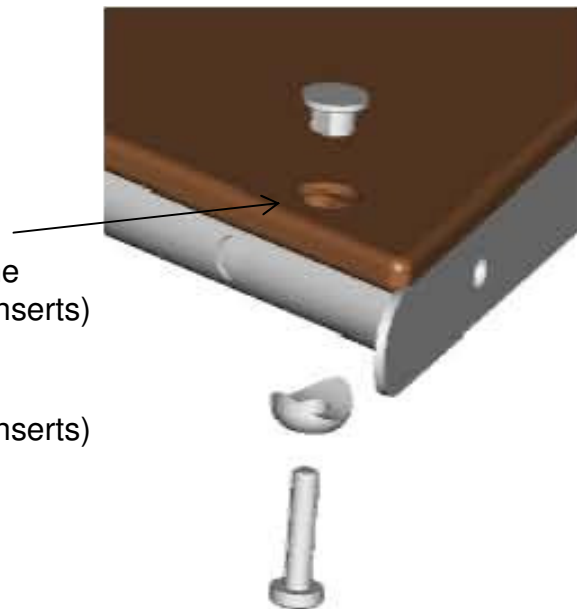

7 **Montering bru m/HPL rekkverk/ Assembly instructions bridge w/HPL railing
/ Montering bro med HPL räcke**

Fest toppen av rekkverket til stolpene med D.89 clamps (enkel eller flere utganger avhengig av konfigurasjonen)

Fasten the top part of the railings using D.89 clamps (single or double depending on the assembly configuration)

Fäst toppen av räcket till stolparna med D.89 clamps (enkel eller flera utgångar avhengig av konfigurationen)

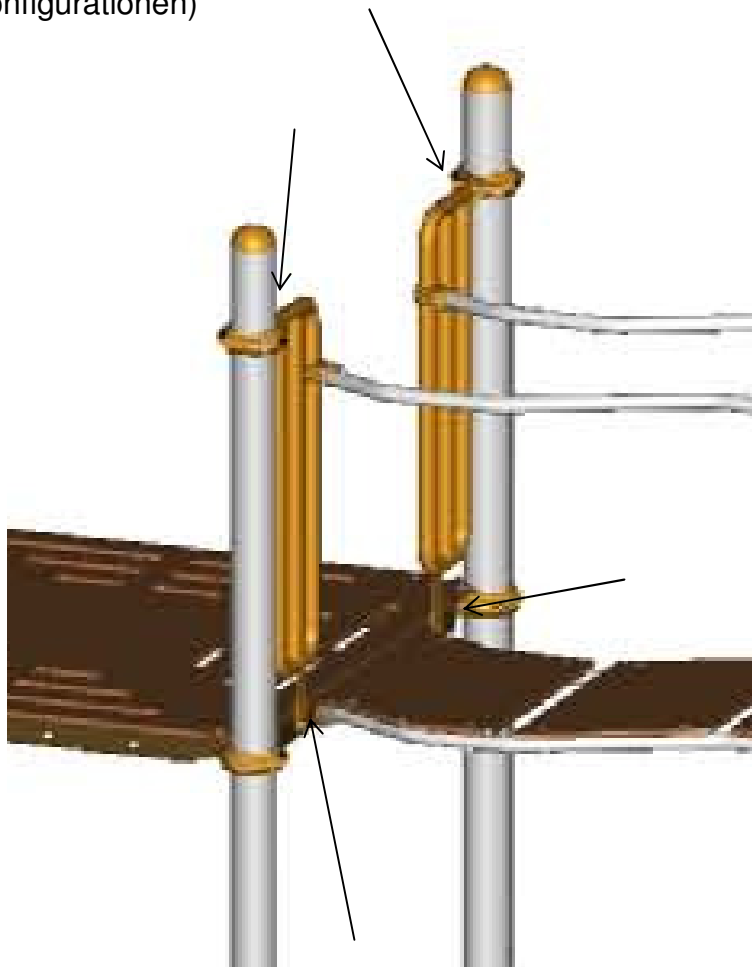

Fest metallrørene til plattformen (M10x30 screws + aluminium torx washer)

Fasten the metal railings onto the platform (M10x30 screws + aluminium torx washer)

Fäst metallrörerna i plattformen (M10x30 skruvar + aluminium torx vasker)

7 **Montering bru m/HPL rekkverk/ Assembly instructions bridge w/HPL railing
/ Montering bro med HPL räcke**

4. Fest brorammen til gulvet på plattformen (M10x55 screws aluminum torx washers)

4. Fix the premounted frame onto the floor (M10x55 screws aluminum torx washers)

4. Fäst broramen till golvet på plattformen (M10x55 screws aluminum torx washers)_

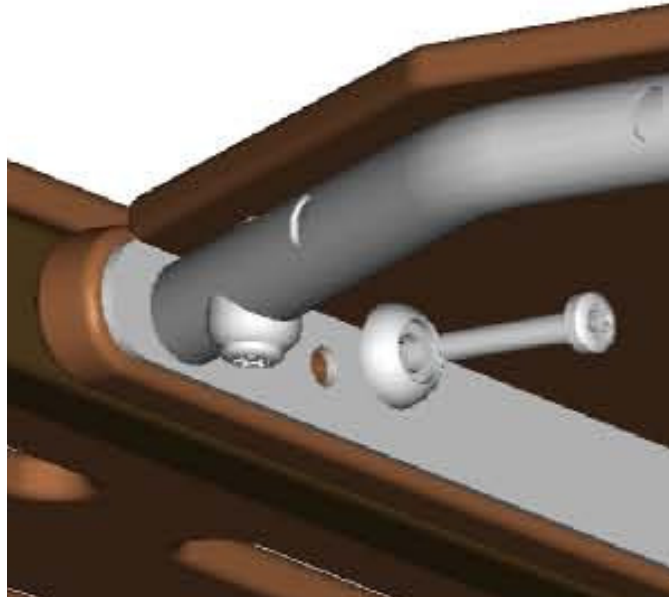

5. Fest de rustfrie stålrørene til metallrammen, men dra ikke til! (D.34 clamps)

5. Fasten the stainless steel handrail tubes onto the metal railing but do not tighten (D.34 clamps)

5. Fäst de rostfria stålrören till metallrammen, men dra inte åt! (D.34 clamps)

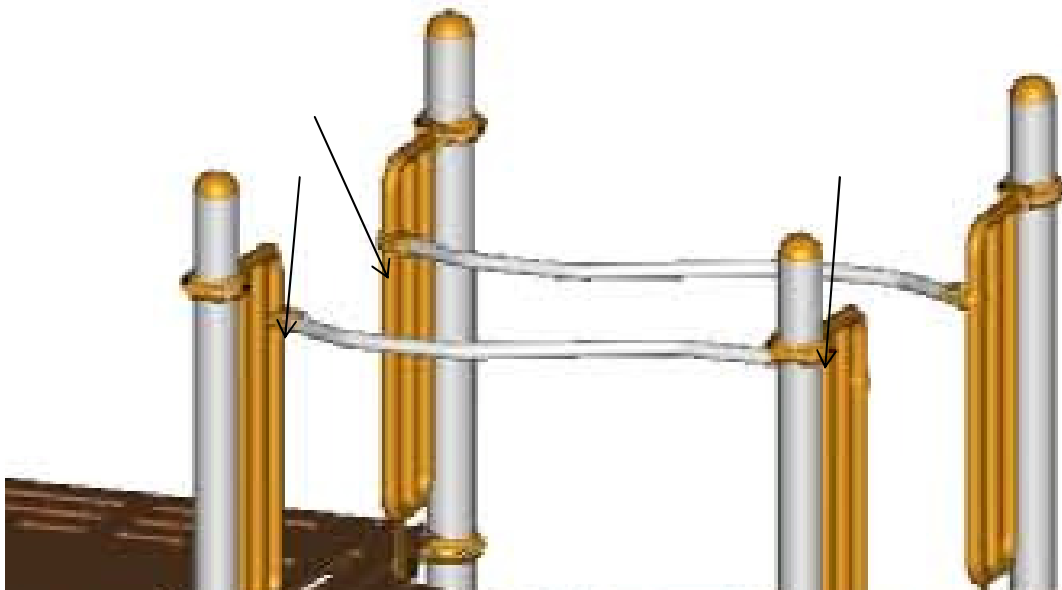

7 Montering bru m/HPL rekkverk/ Assembly instructions bridge w/HPL railing
/ Montering bro med HPL ræcke

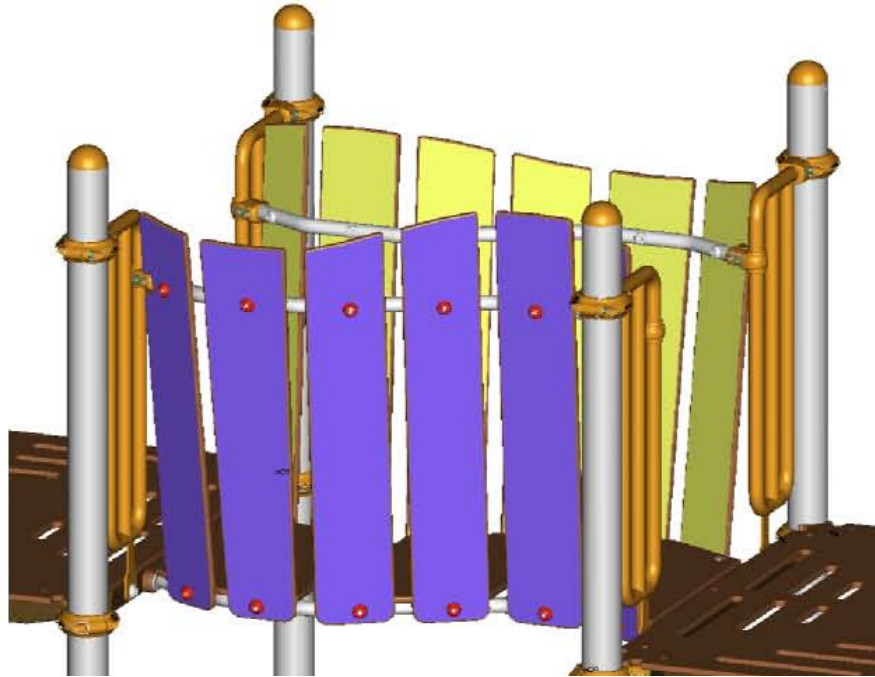

5. Fest HPL platene til metallrørene i riktig rekkefølge (Dette er svært viktig) (M10x55 screws +D.34 clamp ext. Pieces + M cap nuts + red plastic washers)

5. Mount the HPL sides in the order (this is essential) (M10x55 screws +D.34 clamp ext. Pieces + M cap nuts + red plastic washers)

5. Fäst HPL plattorna till metallrören i korrekt följd (Detta är mycket viktig) (M10x55 screws +D.34 clamp ext.. Pieces + M cap nuts + red plastic washers)

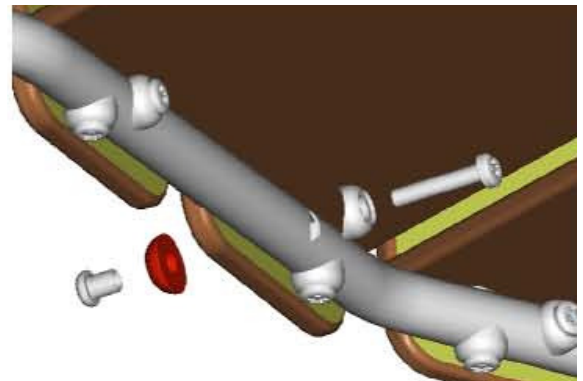

Vær nøye når HPL platene festes(fargene på utsiden skal matche resten av utstyret)
Juster og dra til boltene på hele broen etter montering.

Be careful when fitting the HPL panels (colour outside identical to rest of equipment)
Adjust and tighten the bolts for the whole bridge assembly after complete assembling

Var nogrann när HPL plattorna fästes(färgerna på utsidan skall matcha resten av lekställningen)
Justera och dra åt bultarna på hela bron efter montering.

7

Montering metallbru/ Assembly instructions metalbridge/ Montering metallbro

LIST OF PARTS:

SIDE HR FOR STRAIGHT METAL BRIDGE
1200 JJM-0845-6P

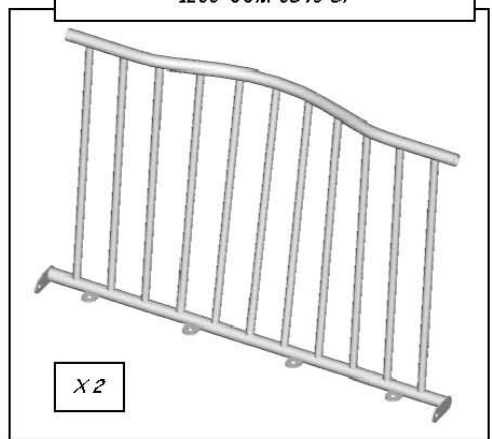

X 2

METAL BRIDGE RAILING-HPL SLIDE ENTRANCE
JJM-0909-6P

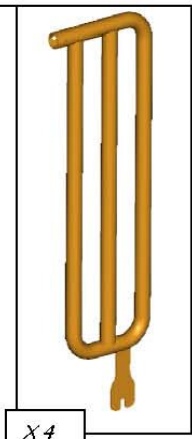

X 4

HPL STRAIGHT PLATFORM FOR METAL
BRIDGE 1200 HPL00436

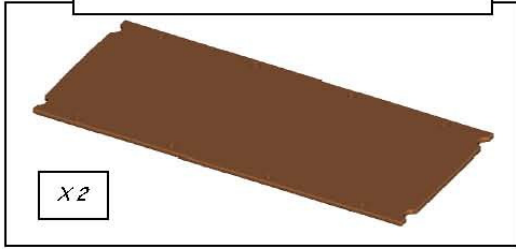

X 2

PRE-EQUIPPED Ø33.7
CLAMP

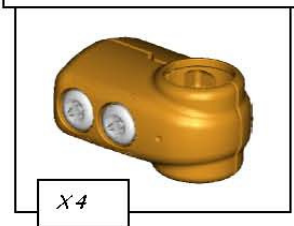

X 4

M10x30 TORX ANTI-TAMPER
SCREW Q00258

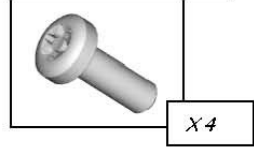

X 4

M10x16 TORX ANTI-TAMPER
SCREW Q00260

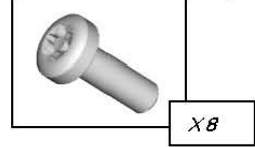

X 8

M10x55 TORX ANTI-TAMPER
SCREW Q00259

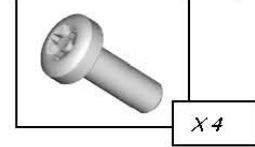

X 4

ALUMINIUMTORX WASHER
Q00753



MOUNTING ONTO TOWER

X 16

STAINLESS STEEL M10 INSERT
Ø25 HT=14MM Q01018

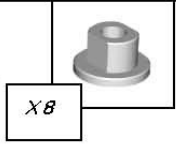

X 8

HPL SHIM TH. 25 S BRIDGE
HPL00381

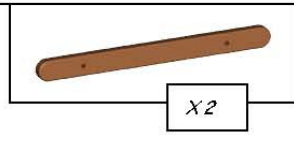

X 2

7**Montering metallbru/ Assembly instructions metalbridge/ Montering metallbro**

- 2) Fest toppen av rekkverket med D.89 clamps (enkel eller dobbel avhengig av konfigurasjonen)
- 2) Fasten the top part of the railing using D.89 clamps (single or double depending on the assembly configuration)
- 2) Fäst toppen av räcket med D.89 clamps (enkel eller dubbel beroende av konfigurationen)

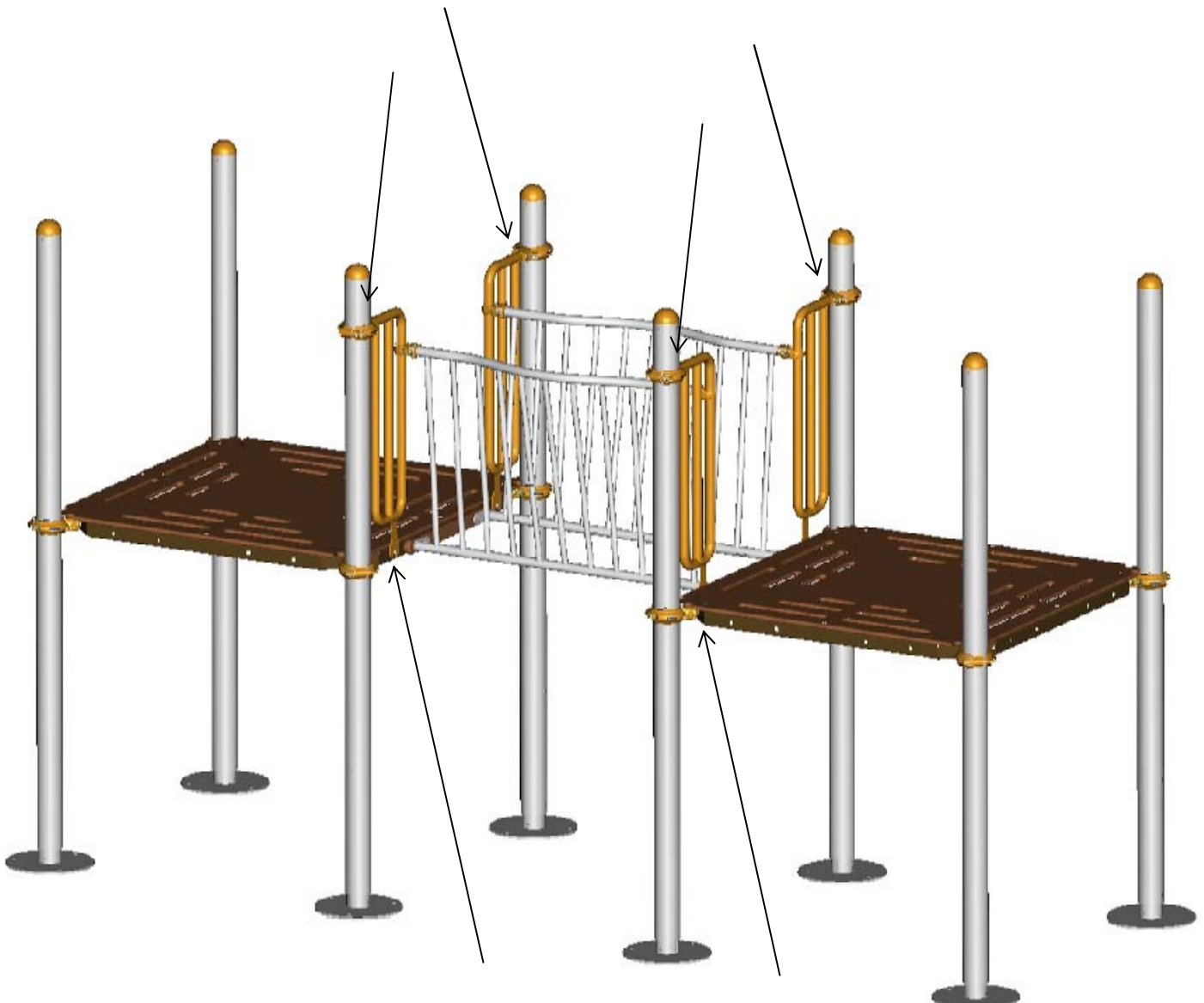

3. Fest metallrekkverket til plattformen (M10x30 screws+aluminium torx washers)
3. Fasten the metal railings onto the platform (M10x30 screws+aluminium torx washers)
3. Fäst metallräcket till plattformen (M10x30 screws+aluminium torx washers)

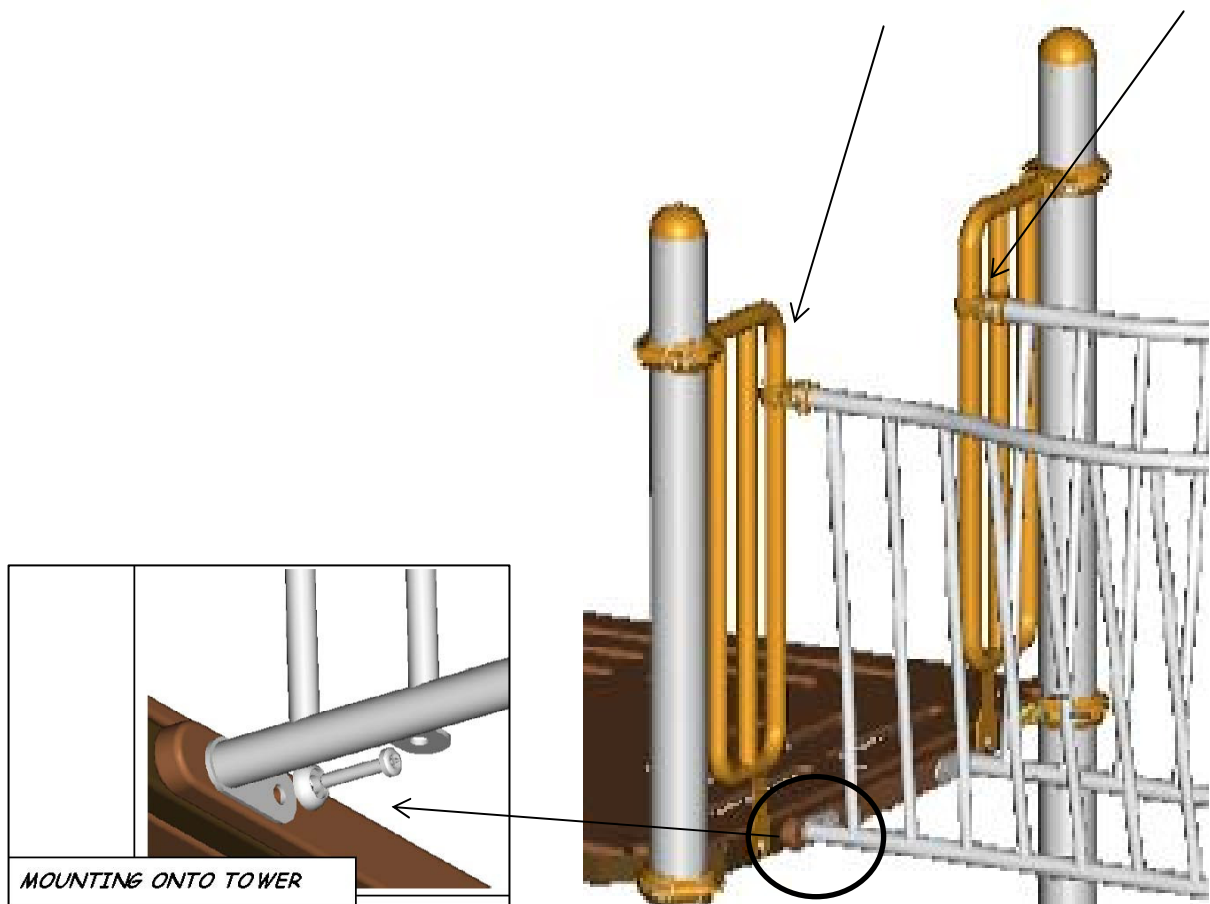
7**Montering metallbru/ Assembly instructions metalbridge/ Montering metallbro**

3) Fest rekkverket til plattformen (M10x55 screws+aluminium torx washers) og enderekkerket(D.34 clamps) uten å dra til
Ikke glem utforing (th.25) mellom plattformen og rammen

3) Mount the side handrails on the platforms without tightening (M10x55 screws+aluminium torx washers) and onto the railings (D.34 clamps)
Do not forget the shim th.25 between the platform and the frame

3) Fäst räcket till plattformen (M10x55 screws+aluminium torx washers) och till ändportalen(D.34 clamps) utan att dra åt
Glöm inte skivan (th.25) mellan plattformen och ramen

7**Montering metallbru/ Assembly instructions metalbridge/ Montering metallbro**

4) Fest HPL broen til rekkverkrammen
(M10x16 screws+aluminium torx washers+stainless steel M10 inserts)

4) Fit the HPL platforms onto the side handrails
(M10x16 screws+aluminium torx washers+stainless steel M10 inserts)

4) Fäst HPL bron till ramen
(M10x16 screws+aluminium torx washers+stainless steel M10 inserts)



Juster og dra til bolter på hele broen når montering er helt ferdig
Monter nøyaktig som vist i anvisningen

Adjust and tighten the bolts for the whole bridge assembly after completely assembling
Assemble strictly as shown in the diagrams

Juster och dra åt bultar på hela bron när monteringen är helt klart
Montera exakt som visas i anvisningen

7

Montering vegg/ Assembly instructions wall/ Montering vägg

(N) MONTERING VEGG

(UK) SIDE PANEL ASSEMBLY

(S) MONTERING VÄGG



7

Montering vegg oppe/ Assembly instructions wall/towerlevel/
Montering vägg tornhöjd

LIST OF PARTS:

AQUATIC SLOTTED HPL 1200 SIDE PANEL
HPL00412

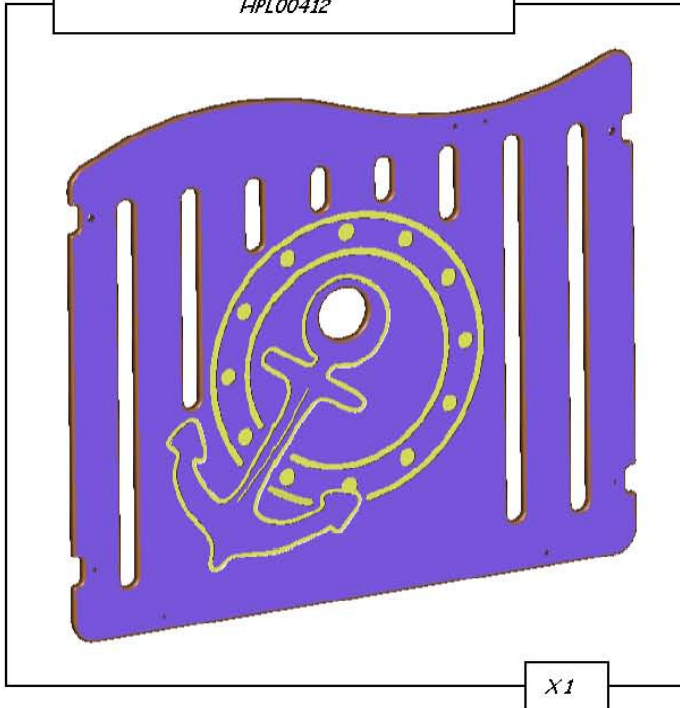

OFFSET MOUNTING BRACKET
JJM-0654-PA

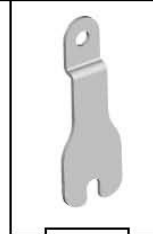

X 2

ALUMINIUM HPL
FASTENING CLIP JMA-

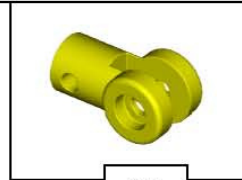

X 2

YELLOW PLASTIC TORX WASHER
Q00755



X 4

ALUMINIUM TORX WASHER
Q00753



X 2

STAINLESS STEEL HM10
NUT Q00299



X 2

M10x20 TORX ANTI-
TAMPER SCREW Q00262



X 2

M10x30 TORX ANTI-
TAMPER SCREW Q00258



X 4

STAINLESS STEEL M10 TORX ANTI-
TAMPER CAPNUT Q00261



X 2

7**Montering vegg oppe/ Assembly instructions wall/towerlevel/
Montering vägg tornhöjd****(N)**

1. Monter veggfestene (JMA-0162-PP) i veggen (M10x30 screws + M10 nuts)
2. Monter braketter (JMA-0654-PA) til veggen (M10x20 screws + torx cap nuts + yellow plastic torx washers) Borr hull D.13.5 til brakettene. Vær nøye med å sette brakettene på riktig side.
3. Fest den sentrerte skiven. (Glem ikke å benytte 2 plastskiver mellom den runde skiven og veggen. Bruk 24mm (JJM-0777-AC) og monter (1 stk 10x20 screw and 1stk M10x16 screw)
4. Skru fast stjerneformet håndtak (screw + nut for knob)
5. Tett hullet for stjerneformet håndtak (M10x16 screw + torx cap nut + yellow plastic torx washers) slik at det ikke er mulig å få fingrene hengene fast i hullet.

(UK)

1. Place the fastening clips in place on the HPL panel (M10x30 screws + M10 nuts)
2. Fix the offset mounting brackets on the HPL panel (M10x20 screws + torx cap nuts + yellow plastic torx washers) Beforehand drill D.13.5 holes for the brackets. Be careful to fix the brackets the right way round so that the picture is on the outside of the equipment.
3. Mount the central disk as shown below. (do not forget the 2 plastic washers between the disk and the themed HPL panel. Put in the 24mm long spacers and faste teh assembly into place with 1 10x20 screw and 1 M10x16 screw
4. Mount the star knob as shown below (screw + nut for knob)
5. Block the screw hole for the star knob (M10x16 screw + torx cap nut + yellow plastic torx washers) so that fingers cannot be trapped in it.

(S)

1. Montera väggfästen (JMA-0162-PP) i väggen (M10x30 screws + M10 nuts)
2. Montera braketter (JMA-0654-PA) till väggen (M10x20 screws + torx cap nuts + yellow plastic torx washers) Borra hål D.13.5 till brakettarna. Noggrant montera brakettene på rätt sida.
3. Montera den sentrerade skivan. (Använd 2 plastskivor mellan den runda skivan och väggen. Använd 24mm (JJM-0777-AC) och montera ihop (1 stk 10x20 screw and 1stk M10x16 screw)
4. Fäst stjärnformad handtak (screw + nut for knob)
5. Plugga hålet för stjärnformad handtak (M10x16 screw + torx cap nut + yellow plastic torx washers) så det inte är möjligt att stoppa fingrarna i hålet

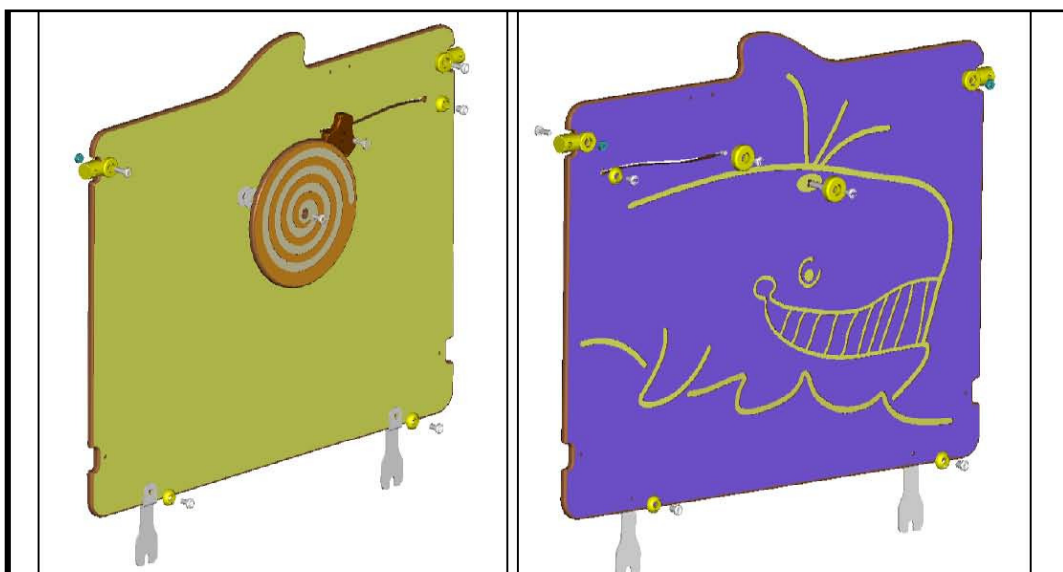

7

Montering vegg oppe/ Assembly instructions wall towerlevel/ Montering vägg tornhöjd

- (N) Monter HPL veggen til stolpene med D.89 klammer (enkel eller tosidig avhenging av konfigurasjonen)
- (UK) Mount the side panel in the top part using D.89 clamps (single or double depending on the assembly configuration)
- (S) Montera HPL väggen til stolparna med D.89 klammer (enkel eller dubbel utgång beroende av konfigurationen)

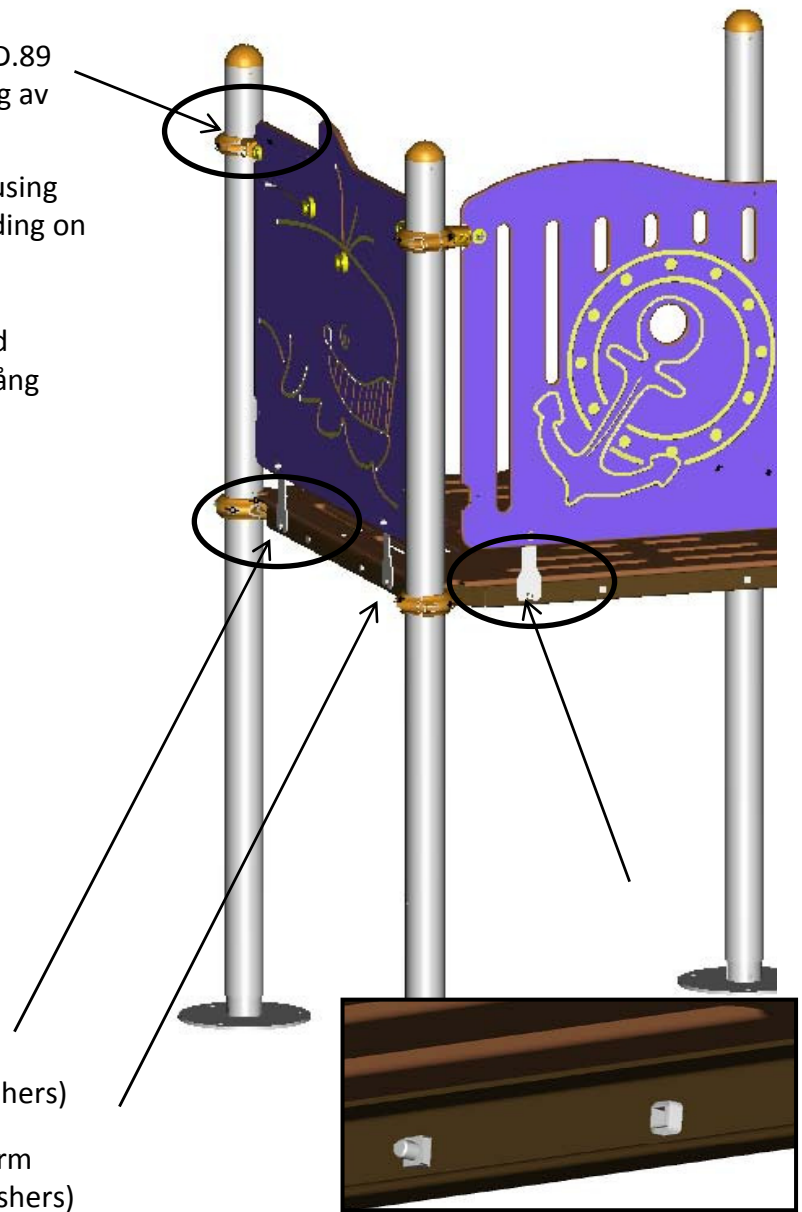

- (N) Monter HPL veggen til gulvet (M10x30 screws + aluminum torx washers)
- (UK) Fix the HPL side panel onto the platform (M10x30 screws + aluminium torx washers)
- (S) Montera HPL väggen till golvet (M10x30 screws + aluminium torx Washers)

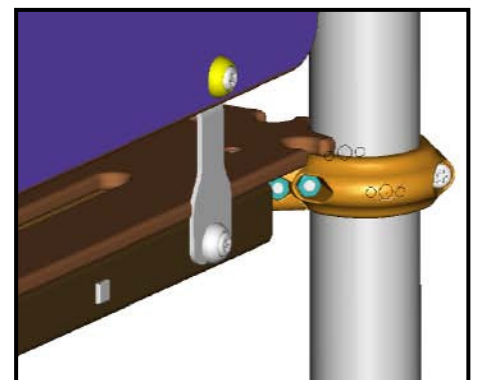
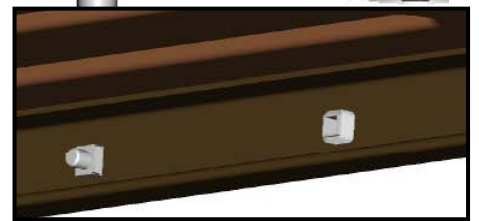

7

Montering vegg nede/ Assembly instructions wall groundlevel/
Montering vägg marknivå

LIST OF PARTS:

POST OFFICE HPL SIDE PANEL
1200 HPL00386

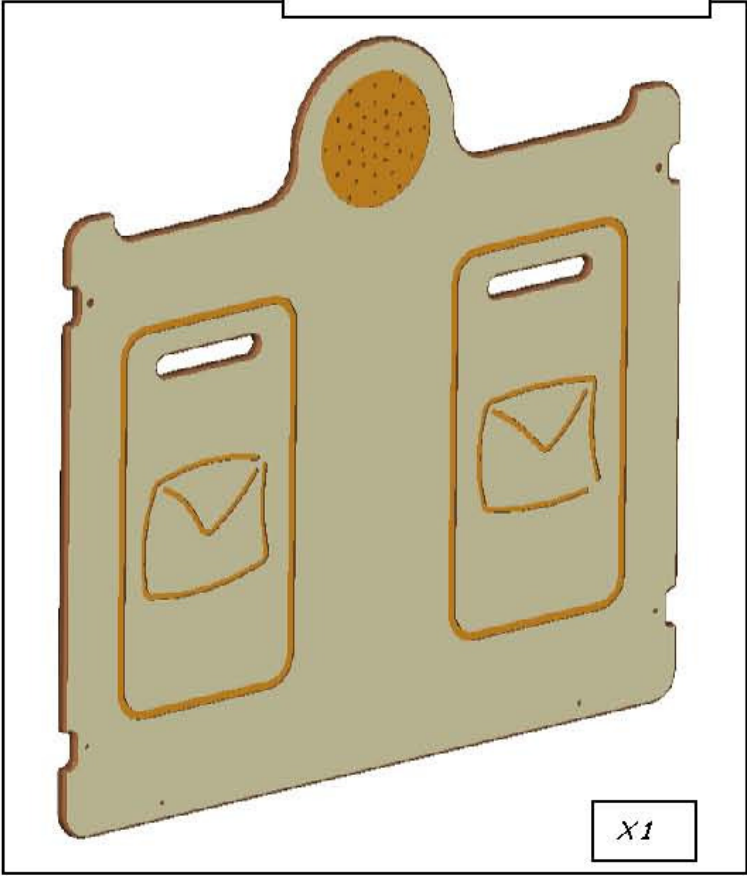

1

ALUMINIUM HPL
FASTENING CLIP JMA-0162-

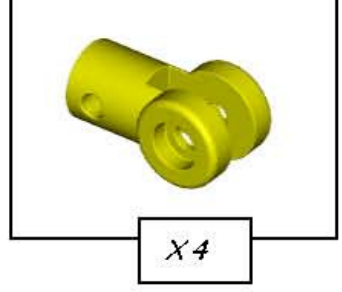

M10x30 TORX ANTI-
TAMPER SCREW Q00258

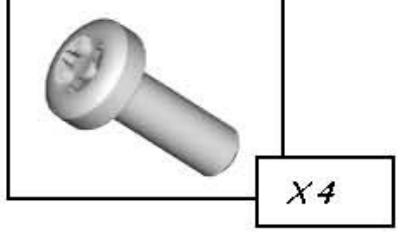

STAINLESS STEEL HM10
NUT Q00299

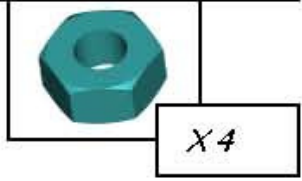

7 Montering vegg nede/ Assembly instructions wall groundlevel/
Montering vägg marknivå

(N) Fest aluminiumsfestene (JMA-0162) til HPL veggen (M10x30 screws + M10 nuts) i de forhåndborrede hullene D11 for å feste til nederste del.

(UK) Put the fastening clips in place on the HPL panel (M10x30 screws + M10 nuts) beforehand drill D11 holes for the bottom fastening clips

(S) Montera aluminiumsfästen (JMA-0162) till HPL väggen (M10x30 screws + M10 nuts) i de förhandsborrade hålen D11 för att fästa bottendelen

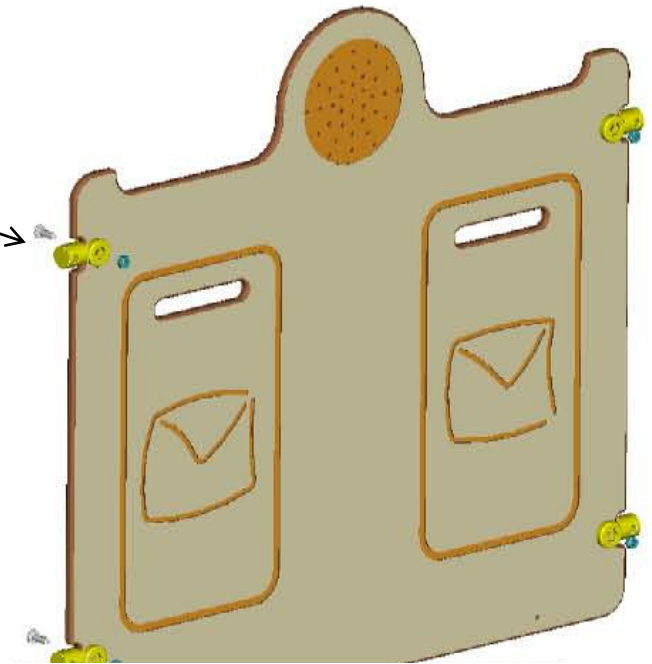

(N) Monter veggen til stolpene med D.89 klammer. (Enkel eller tosidig klamme avhengig av konfigurasjonen)

(UK) Mount the side panel using D.89 clamps. (Single or double depending on the configuration)

(S) Montera väggen till stolparna med D.89 klammor. (Enkel eller dubbel utgång beroende på konfigurationen)

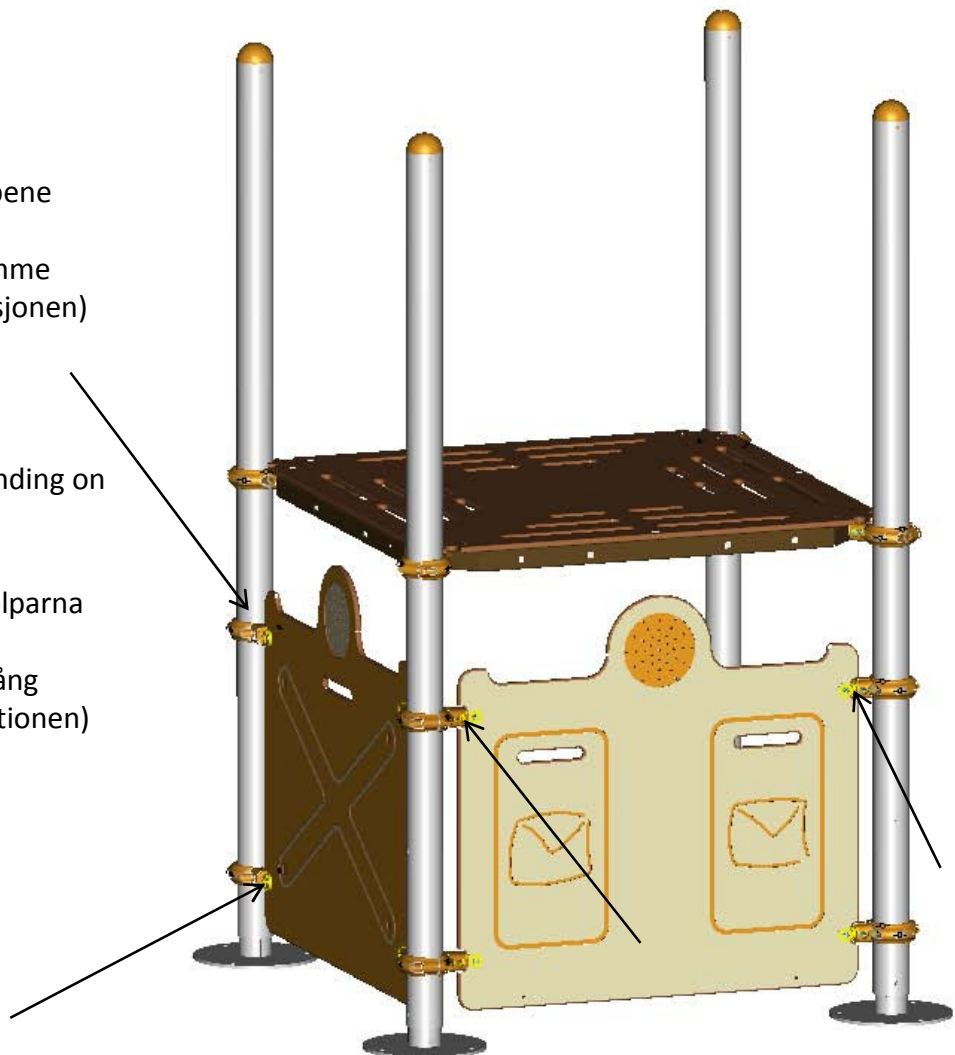

7

Montering benk&bord/ Assembly instructions bench/ Montering bänk&bord

LIST OF PARTS:

CAMELEO BENCH-TABLE FRAME
JJM-862-GP

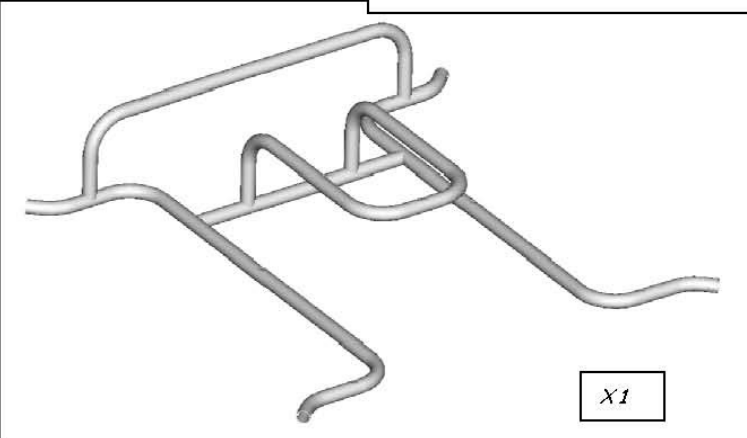

X1

STAINLESS STEEL M10 INSERT
Ø25 HT=14MM



X9

D.89 CLAMP WITH 1 PRE-EQUIPPED
FASTENING JPI-0081-KI



X4

LEFT HPL BENCH FOR CAMELEO HOUSE
HPL00446

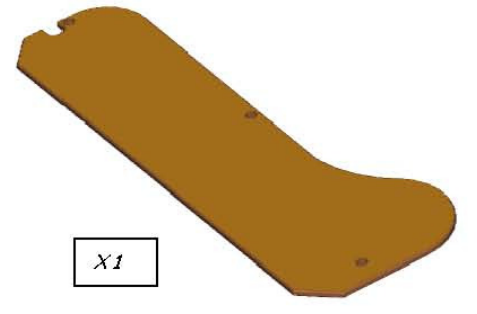

X1

D.34 CLAMP EXT. PART
JCO-0170-PP



X9

M10x45 TORX ANTI-TAMPER
SCREW Q01045



X9

RIGHT HPL BENCH FOR CAMELEO HOUSE

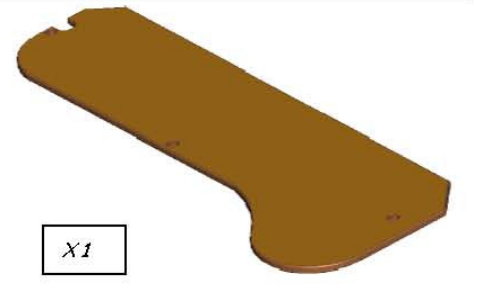

X1

HPL TABLE FOR CAMELEO HOUSE
HPL00445

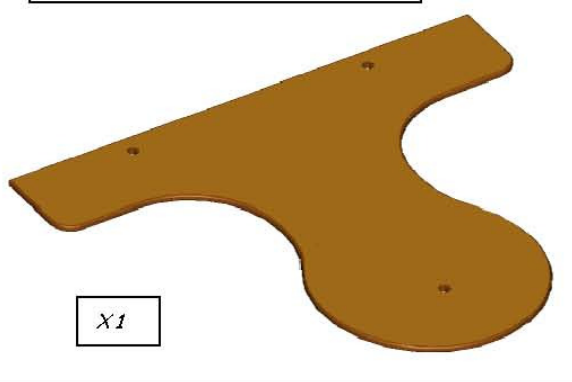

X1

7 Montering benk&bord/ Assembly instructions bench/ Montering bänk&bord

(N) Fest HPL platene til metallrammen
(M10x 45 screws + stainless steel M10
inserts D. 34 clamps inserts)

(UK) Fasten the HPL panels onto the metal frame
(M10x 45 screws + stainless steel M10
inserts D. 34 clamps inserts)

(S) Fäst HPL plattorna till metallramen
(M10x 45 screws + stainless steel M10
inserts D. 34 clamps inserts)

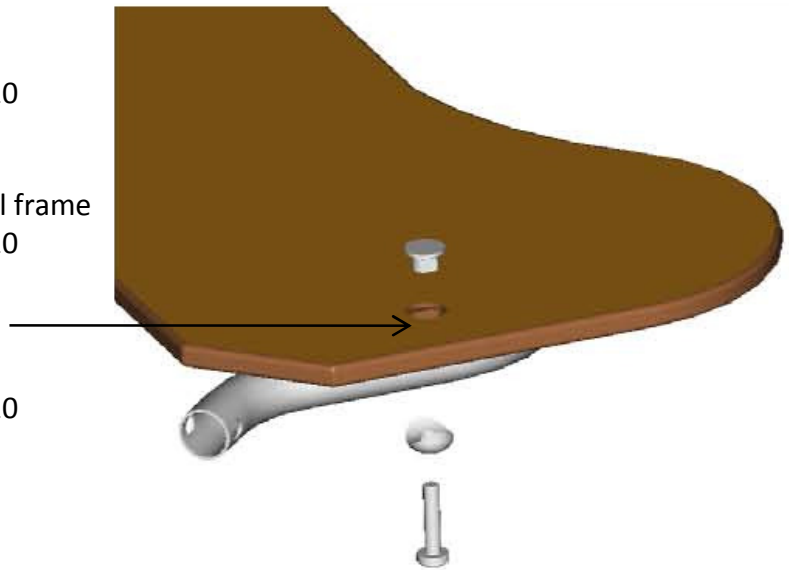

(N) Fest benk/bord til nedre del av stolpene med (D.89 klammer med 1 festeordning)
NB! Toppen av bordet må ikke være over 600mm fra bakken med eller uten golv.

(UK) Fasten the bench table unit onto the lower level of the tower only(D.89 clamps with 1 fastening
NB! The top of the table must be lower than 600mm from the ground with or without an inside
floor

(S) Fäst bänk/bord till nedre delen av stolparna med (D.89 klämmor med 1 fästeanordning)
OBS! Toppen av bordet får inte vara över 600 mm marknivå med eller utan golv.

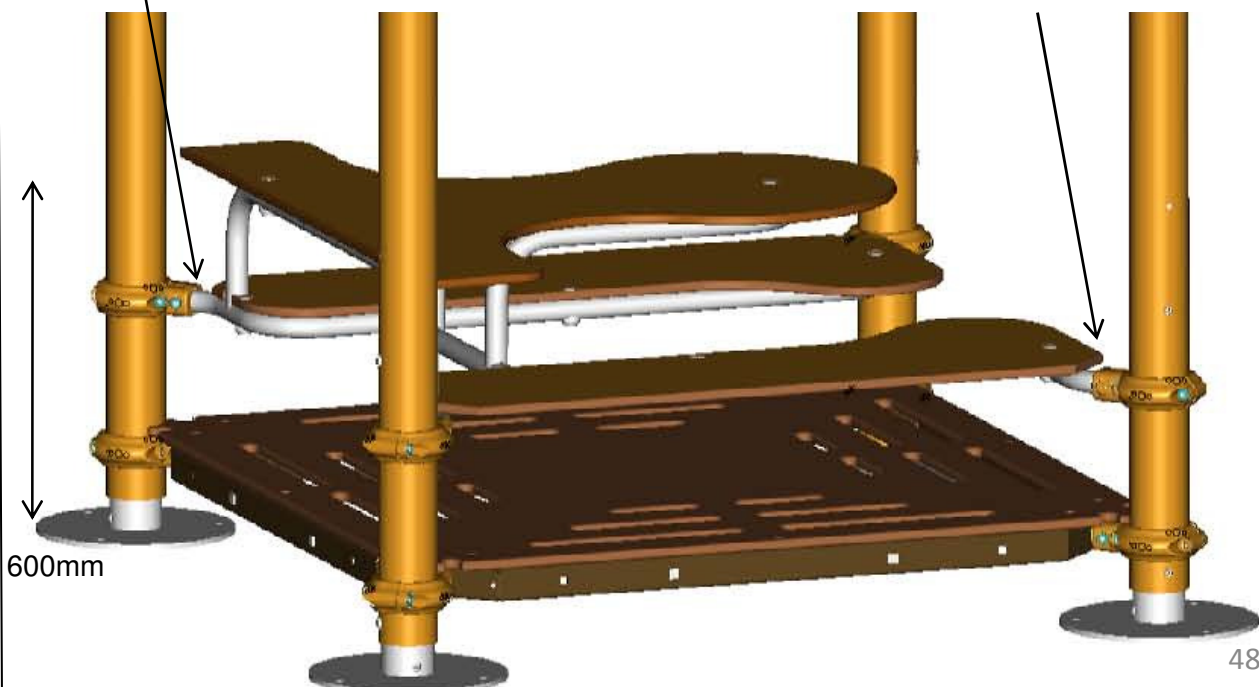

7

Montering trapp/ Assembly instructions stair/ Montering trappa

LIST OF PARTS:

*PRE-EQUIPPED EASY LADDER
HT1200 JJM-0724-EQ*



X1

*METAL RAILING WITH LARGE LOOP ENTRANCE
JJM-0646-6P*

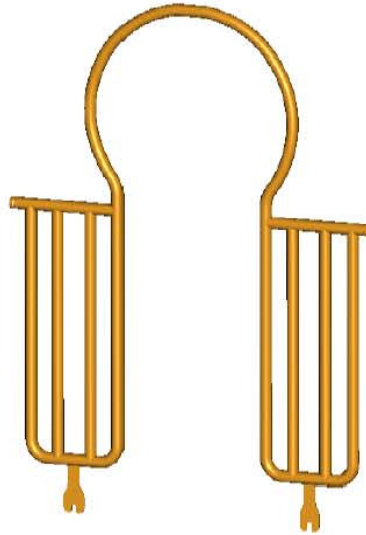

X1

*EASY LADDER HR TUBE HT1200
JJM-0726-PA*



X2

*ALUMINIUM TORX WASHER
Q00753*



X4

*LADDER ANCHORING BRACKET INCL. LEV. 0
JPI-0142-PA*



X1

M10x30 TORX ANTI-TAMPER SCREW Q00258



X6

*D.34 CLAMP EXT. PIECE
JCO-0170-PP*



X4

*Ø33.7 PRE-EQUIPPED CLAMP
JPI-0076-KI*



X2

M10x45 TORX ANTI-TAMPER SCREW Q01045



X2

*STAINLESS STEEL HM10
NUT Q00299*



X2

7

Montering trapp/ Assembly instructions stair/ Montering trappa

(N) Fest portal til stolpene med D.89 klammer (enkel eller tosidig avhengig av konfigurasjonen)

(UK) Fasten the top part of the railing using D.89 clamps (single or double depending on the assembly configuration)

(S) Fäst portal till stolparna med D.89 klammer (enkel eller dubbel utgång beroende av konfigurationen)

(N) Fest portal til gulv (M10x30 screws + aluminium torx washers)

(UK) Fasten the metal railing onto the platform (M10x30 screws + aluminium torx washers)

(S) Fäst portal till golvet (M10x30 screws + aluminium torx washers)

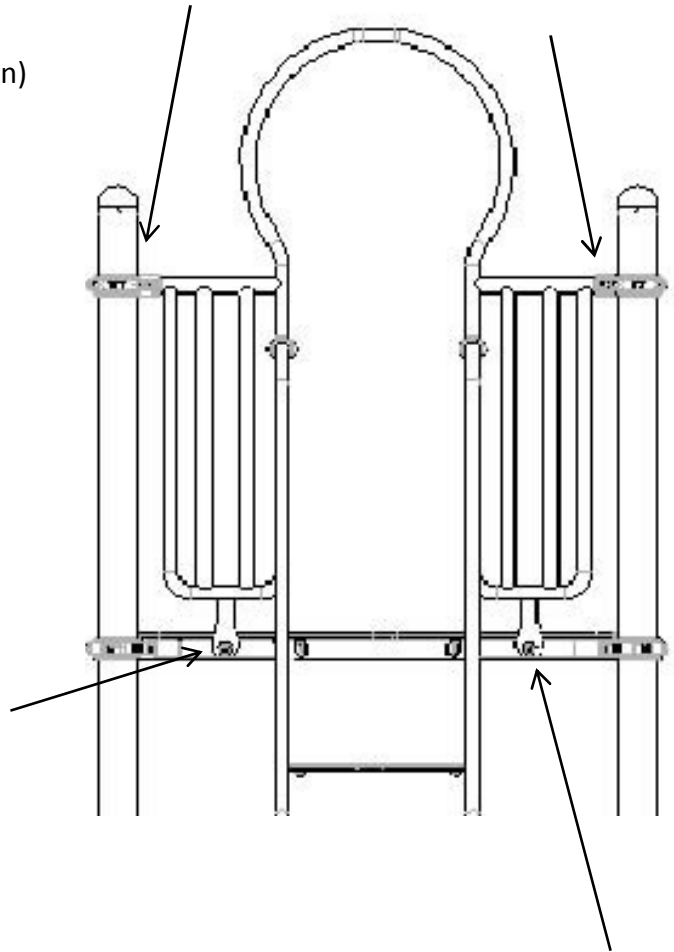

(N) Fest ankerfestet til trapp (M10x30 screw + D.34 clamp ext. Piece)

(UK) Fit the anchoring bracket onto the pre-equipped easy ladder (M10x30 screw + D.34 clamp ext. Piece)

(S) Montera ankarfästet till trappan (M10x30 screw + D.34 clamp ext. Piece)

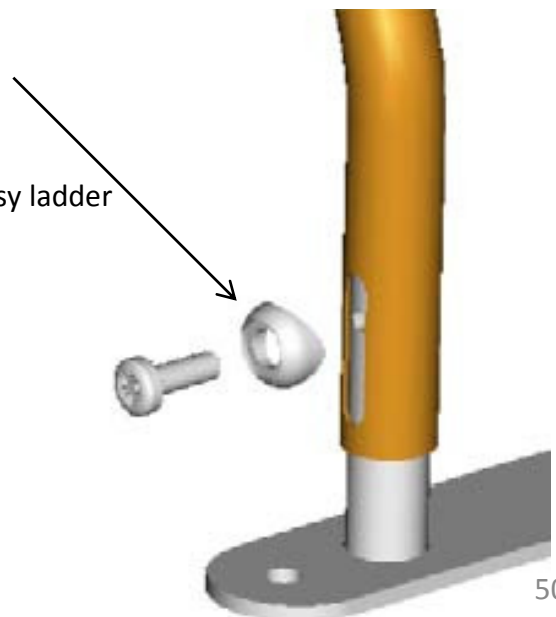

7

Montering trapp/ Assembly instructions stair/ Montering trappa

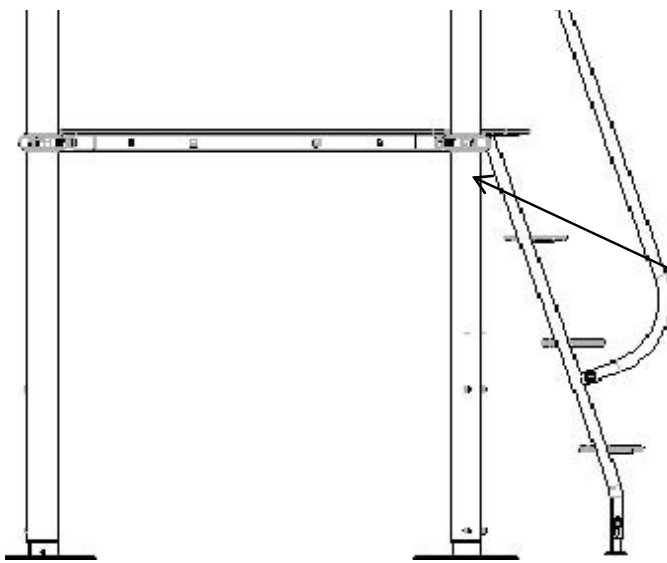

- (N) Monter trapp til gulvet (M10x30 screws + aluminium torx washers)
- (UK) Fix the easy ladder onto the platform (M10x30 screws + aluminium torx washers)
- (S) Montera trappan till golvet (M10x30 screws + aluminium torx washers)

- (N) Fest rekkverket til portalen (pre-equipped D.34 clamps)
- (UK) Mount the handrail tubes onto the railing (pre-equipped D.34 clamps)
- (S) Fäst räcket till portalen (pre-equipped D.34 clamps)



- (N) Fest rekkverk til trappen (M10x45 screws + D34 clamp ext. pieces + M10 nuts)
- (UK) On the pre-equipped ladder (M10x45 screws + D34 clamp ext. pieces + M10 nuts)
- (S) Fäst räcket till trappan (M10x45 screws + D34 clamp ext. pieces + M10 nuts)

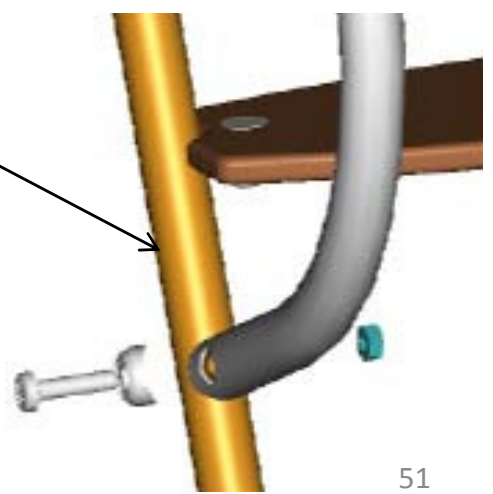

7

Montering trapp/ Assembly instructions stair/ Montering trappa

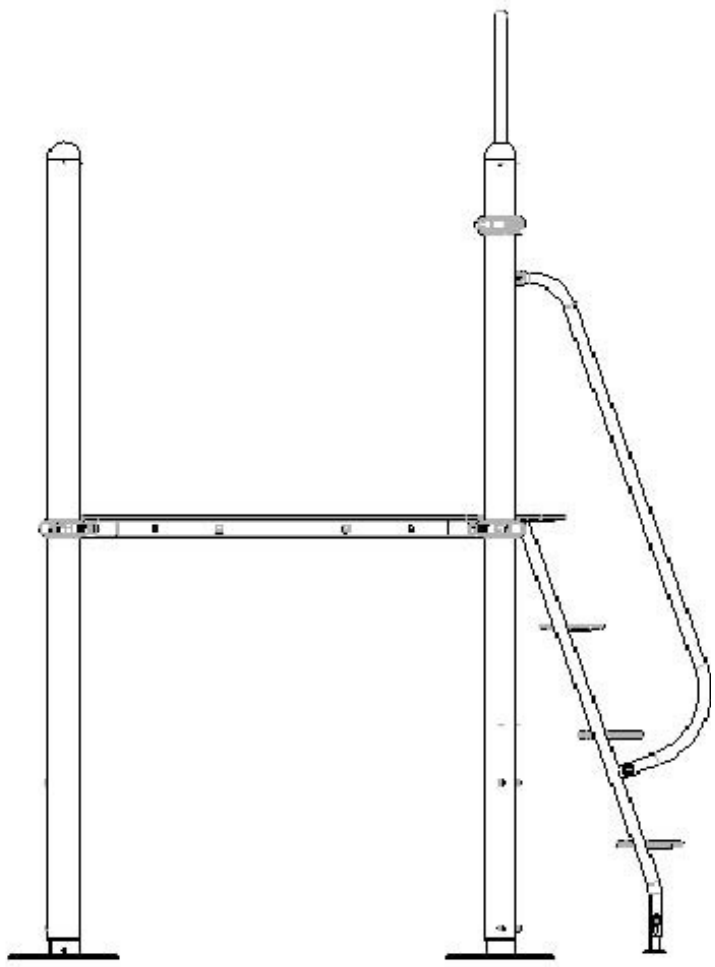
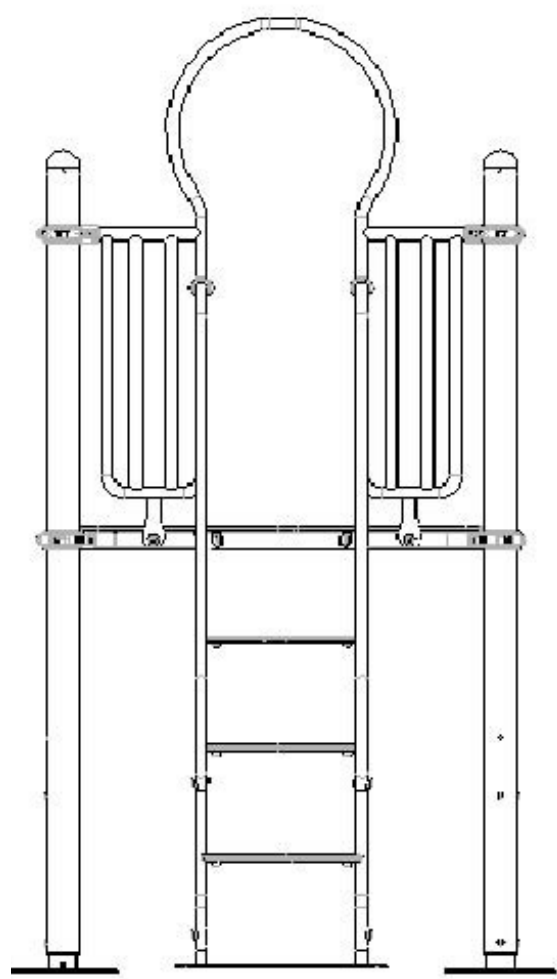

7

Montering klatrenett/ Assembly instructions net/Montering klätternät

LIST OF PARTS:

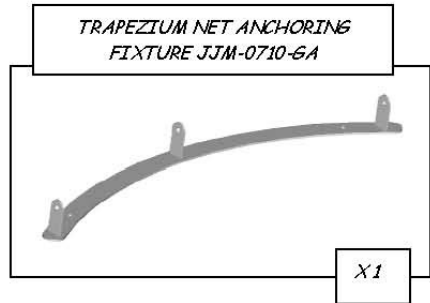
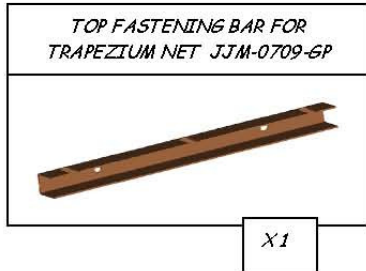
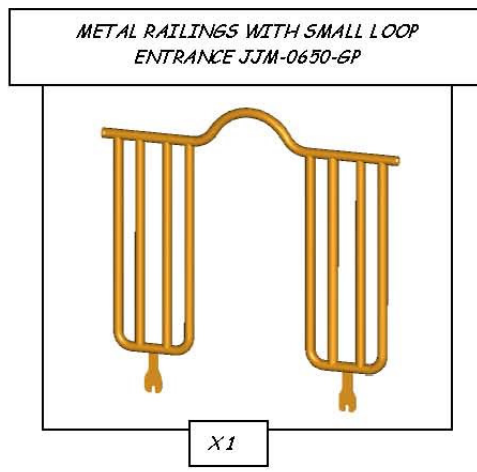
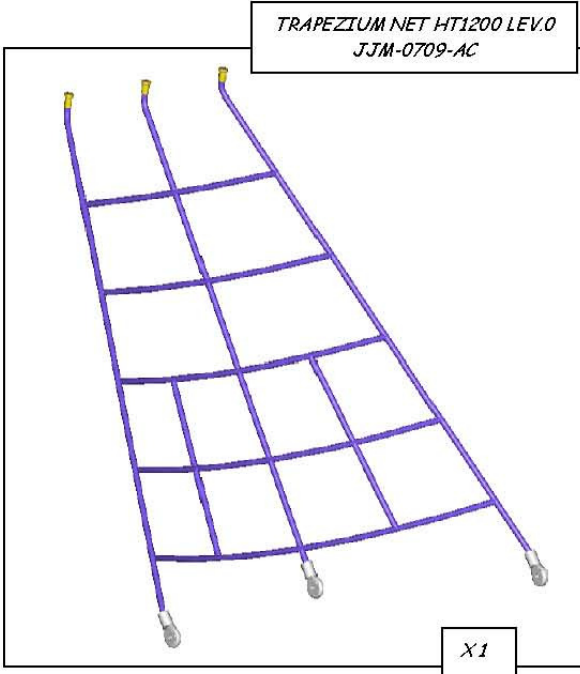

INSTRUCTIONS APPLICABLE TO THE FOLLOWING PARTS

TRAPEZIUM NET HT1200 LEV 0 REF JJM-0709-00
TRAPEZIUM NET HT1200 LEV -40 REF JJM-0709-40

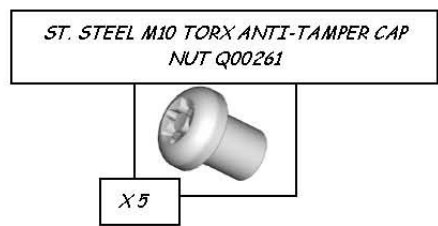

7 Montering klatrenett/ Assembly instructions net/Montering klätternät

(N) Fest portal til stolpene med D.89 klammer
(enkel eller tosidig avhengig av konfigurasjonen)

(UK) Fasten the top part of the railing using D.89
clamps (single or double depending on the
assembly configuration)

(S) Fäst portal till stolparna med D.89 klammer
(enkel eller dubbel utgång beroende av konfigurationen)

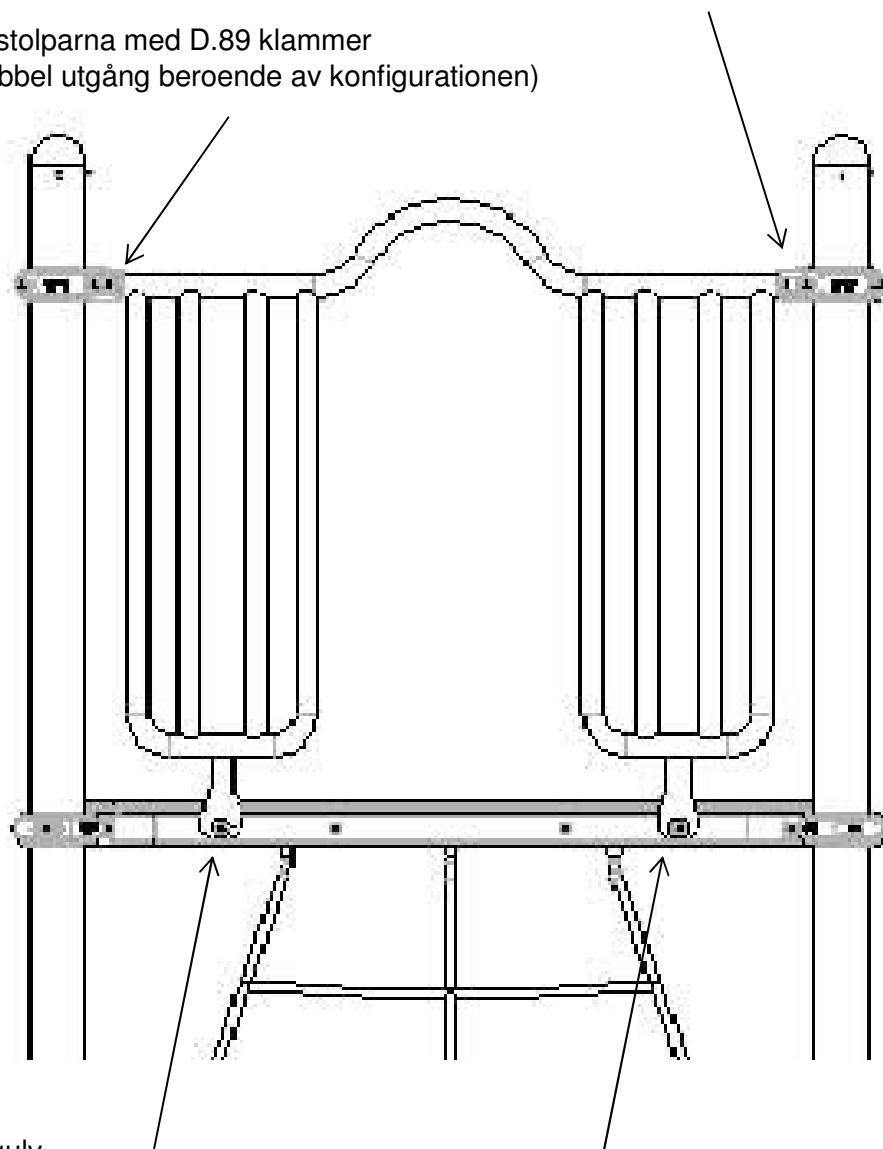

(N) Fest portal til gulv
(M10x30 screws + aluminium torx washers)

(UK) Fasten the metal railing onto the platform
(M10x30 screws + aluminium torx washers)

(S) Fäst portal till golvet
(M10x30 screws + aluminium torx washers)

7 Montering klatrenett/ Assembly instructions net/Montering klätternät

(N) Fest nettet til forankringen
(M10x20 screws + M10 torx cap nuts + aluminum torx washers)

(UK) Fasten the trapezium net to the anchoring fixture
(M10x20 screws + M10 torx cap nuts + aluminum torx washers)

(S) Fäst nätet till förankringen
(M10x20 screws + M10 torx cap nuts + aluminum torx washers)

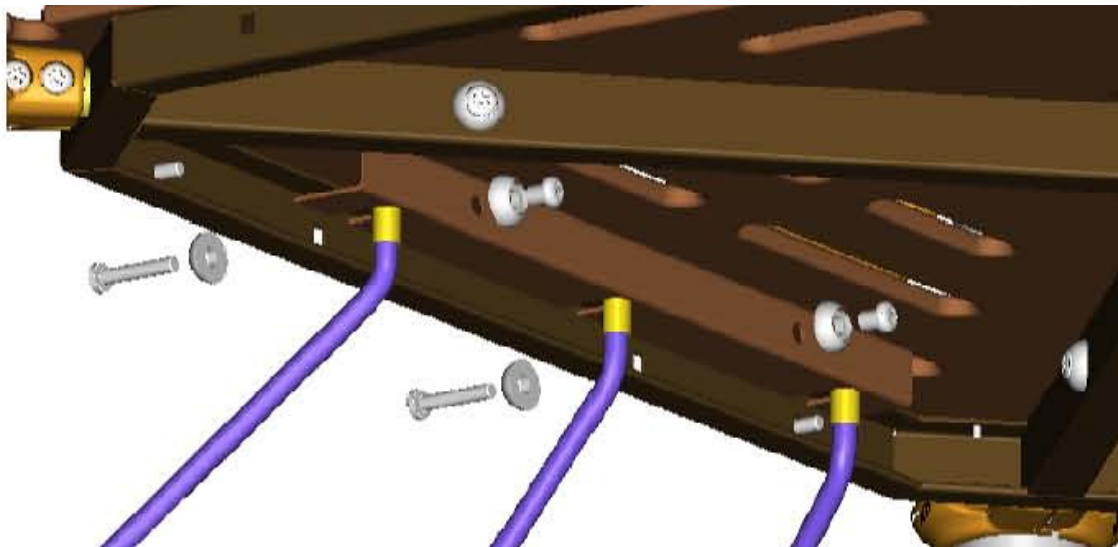
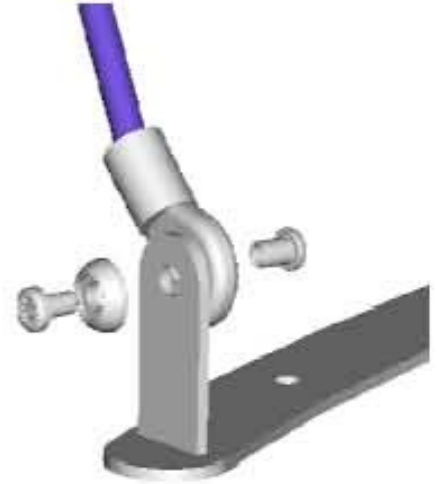

(N) Fest nettet til plattformen
-Fest nettet til metalfestet (JJM 0709 6P)
- Legg denne på innsiden av plattformrammen
- Bolt sammen(M10x55 screws + aluminum torx washers + M10 torx cap nuts)

(UK) Fix the trapezium net on the platform
-Slot the net rope strand into the grooves of the fitting (JJM 0709 6P)
- Position this assembly against the inside of the platform frame
- Bolt together (M10x55 screws + aluminum torx washers + M10 torx cap nuts)

(S) Fäst nätet till plattformen
-Fäst nätet till metalfästet(JJM 0709 6P)
- Placera denna på insidan av plattformramen
- Bult ihop(M10x55 screws + aluminum torx washers + M10 torx cap nuts)

Montering rutsjebane/ Assembly instructions slides / Montering rutschkana

LIST OF PARTS:

ANCHORING FIXTURE LEV.0
DOUBLE SLIDE JIN-0076-PA

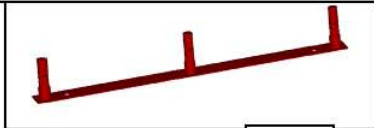

X1

PRE-EQUIPPED D.89 CLAMP WITH &
FASTENING JPI-0081-KI



X2

DOUBLE SLIDE HT1200/PLATFORM
JIN-0238-EQ

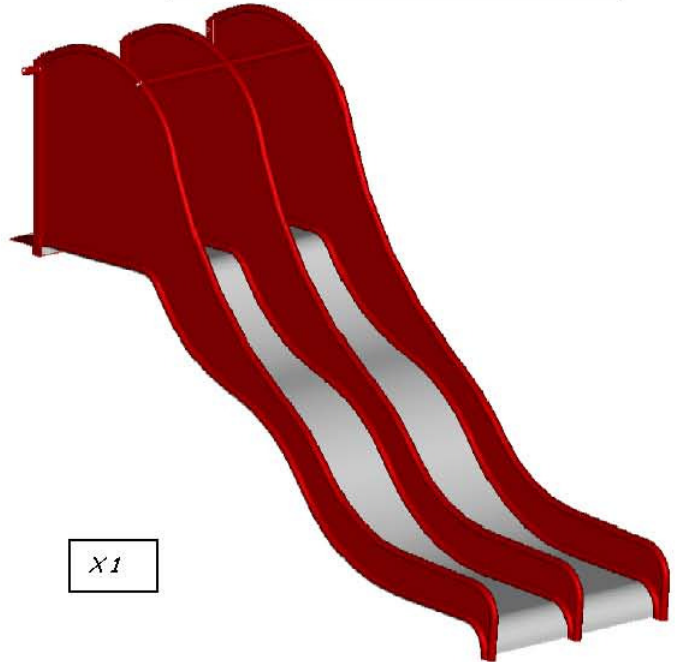

X1

STAINLESS STEEL M10 TORX ANTI-
TAMPER CAP NUT Q00261



X2

M10x16 TORX ANTI-TAMPER
SCREW Q00260



X3

D.34 CLAMP EXT. PIECE
JCO-0170-PP



X3

ALUMINIUM TORX WASHER
Q00753



X4

M10x20 TORX ANTI-
TAMPER SCREW Q00262



X2

7 Montering rutsjebane/ Assembly instructions slides / Montering rutschkana

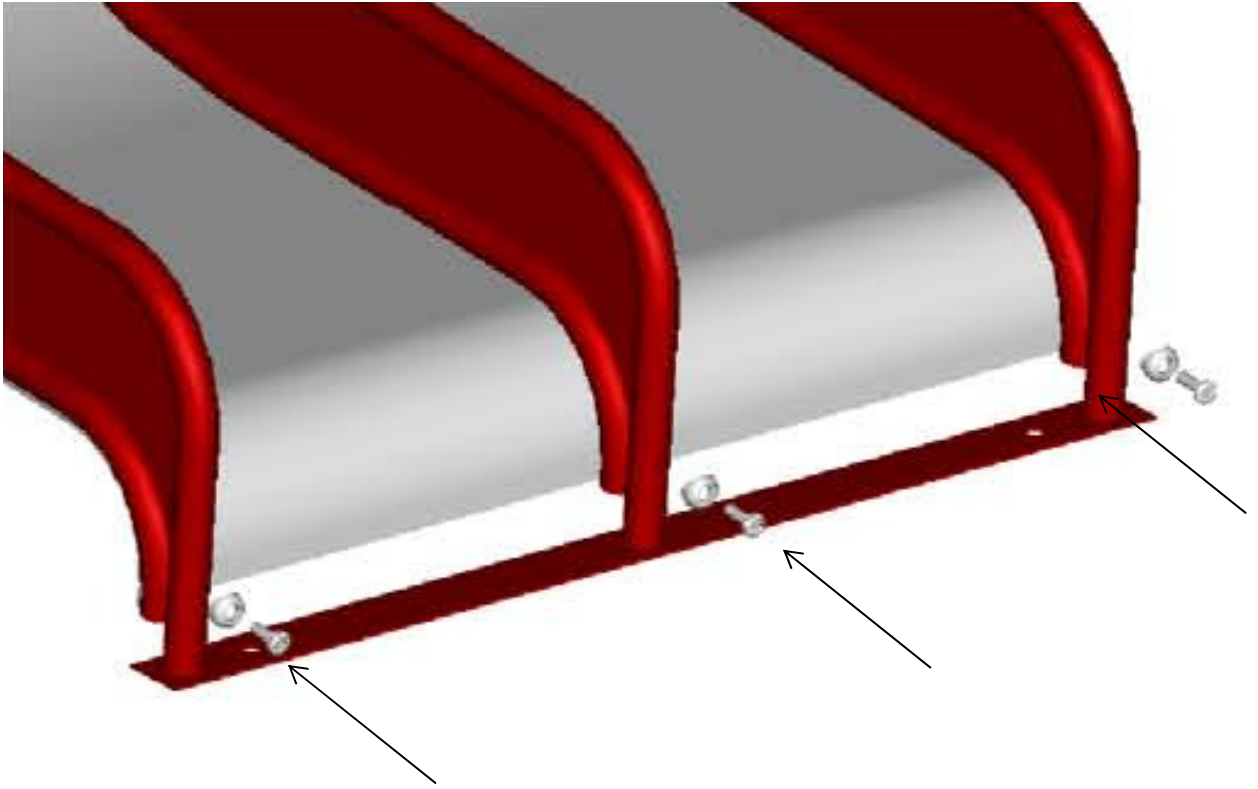

1. Fest ankerplaten til sklien (M10x16 screws + D.34 clamp ext. Pieces)
1. Fit the anchoring fixture onto the slide (M10x16 screws + D.34 clamp ext. Pieces)
1. Fäst ankarplattan till rutchkanan (M10x16 screws + D.34 clamp ext. Pieces)

7 Montering rutsjebane/ Assembly instructions slides / Montering rutschkana

2. Legg sklien på plattformen, og plasser festet på siden av plattformen
2. Place the slide on the platform, place the adaptor right up against the side of the platform
2. Placera rutchkanan på plattformen, och placera fästen på sidan av plattformen

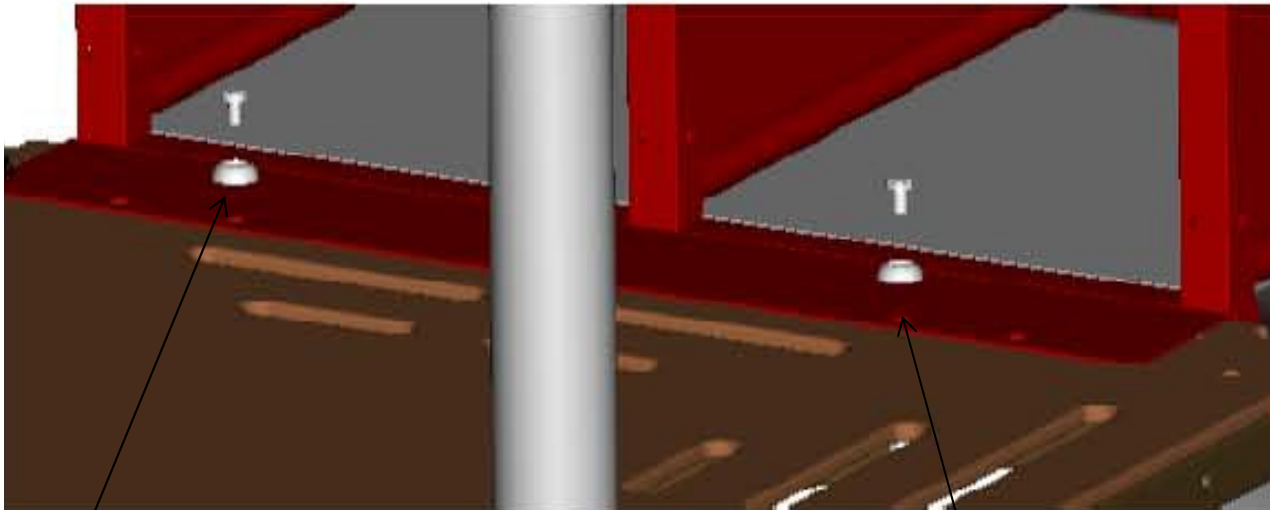

3. Borr festebeslaget D.13.5 og fest sklien
(M10x20 screws + aluminum torx washer + M10 torx cap nut)
3. Drill the adapter D.13.5 and fasten the slide down
(M10x20 screws + aluminum torx washer + M10 torx cap nut)
3. Borra fästbeslaget D.13.5 och montera fast rutchkanan
(M10x20 screws + aluminum torx washer + M10 torx cap nut)

7

Montering rutsjebane/ Assembly instructions slides / Montering rutschkana

4. Fest sklien til stolpene med D.89 klammer med 1 festpunkt

4. Fix the slide onto the posts using D.89 clamps with 1 fastening

4. Montera fast rutchkanan i stolparna med D.89 klammer med 1 fästpunkt

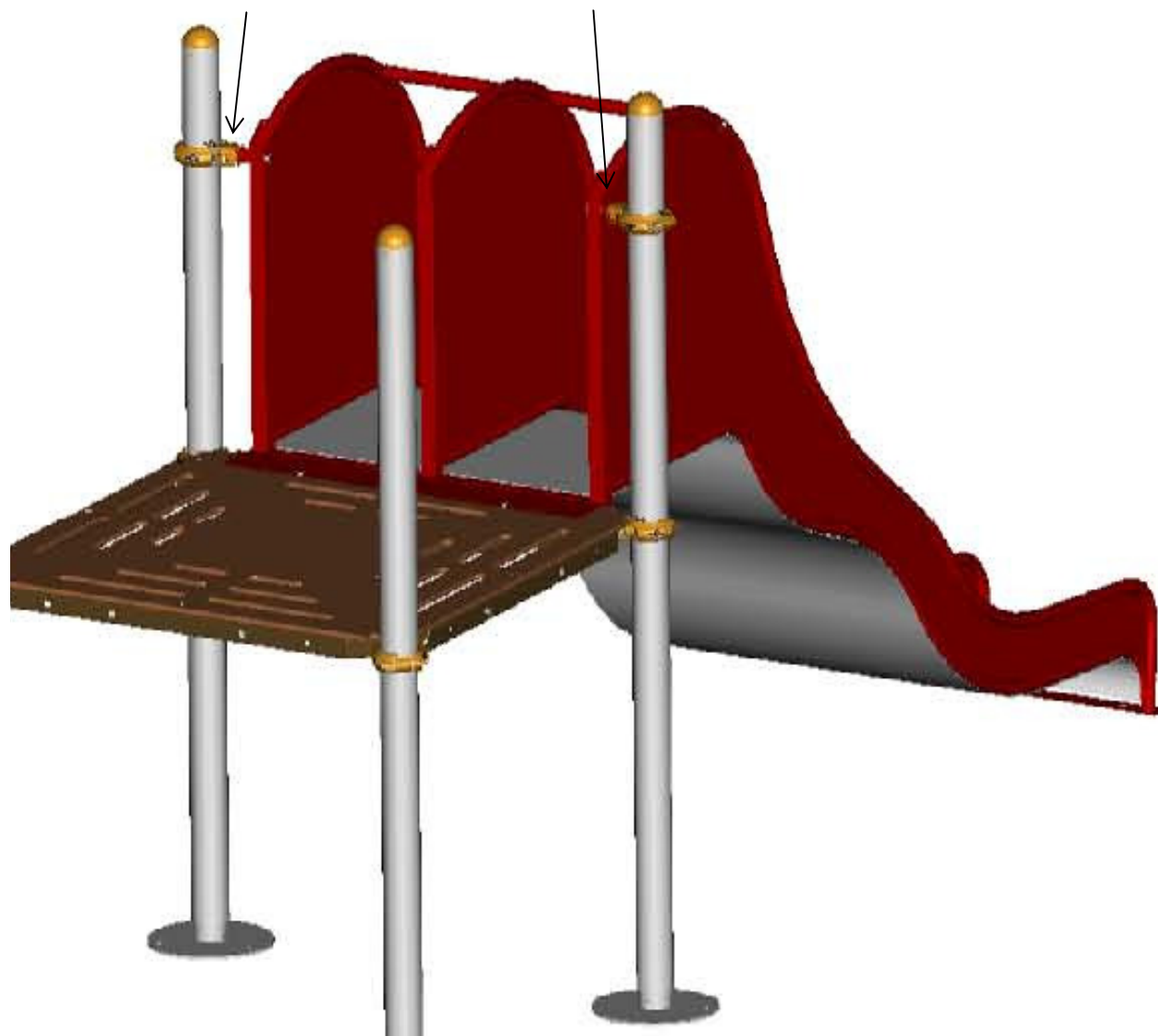

Monter nøyaktig slik som vist

Assembly strictly as shown in the diagrams

Montera exakt så som visas

**Montering brannmannstang/ Assembly instructions firemans pole/
Montering brandmanstång**

Montering brannmannstang

Fireman´s pole assembly

Montering brandmanstång



LIST OF PARTS:

FIREMAN'S POLE HT 1200
JJM-0675-PA

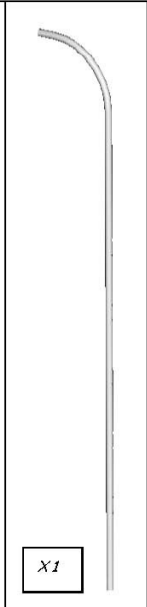

X1

M10x30 TORX ANTI-TAMPER SCREW Q0025B



X3

ALUMINIUM TORX WASHER Q00753



X2

D.34 CLAMP EXT. PIECE JCC-0170-PP



X1

ANCHOR PLATE FOR D33.7 LEV:0 JPI-0004-PA



X1

METAL RAILING WITH LARGE LOOP ENTRANCE JJM-0646-6P

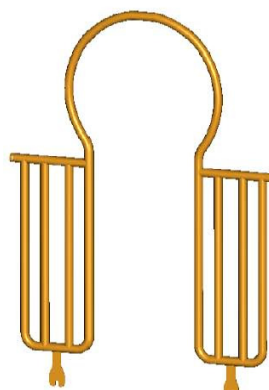

X1

PRE-EQUIPPED Ø33.7 CLAMP JPI-0076-KI



X1

7 Montering brannmannstang/ Assembly instructions / Montering av brandmanstång

(N) Fest portal for brannmannstang i stolpene med D.89 klammer (enkel eller tosidig avhengig av konfigurasjonen)

(UK) Fasten the top part of the railing using D.89 clamps (single or double depending on the assembly configuration)

(S) Fäst portal till brandmanstång i stolparna med D.89 klämmor (enkel eller dubbel utgång beroende av konfigurationen)

(N) Fest portal for brannmannstang til gulvet med (M10x30mm screws + aluminum torx washers)

(UK) Fasten the metal onto the platform (M10x30mm screws + aluminum torx washers)

(S) Fäst portal för brandmanstång till golvet med (M10x30mm screws + aluminum torx washers)

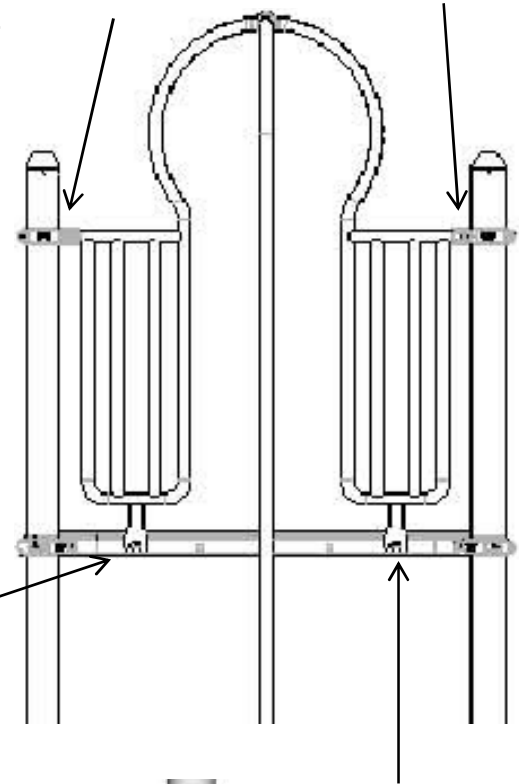

(N) Fest forankringsplaten til brannmannstangen (M10x30 mm screws + D.34 ext. Piece)

(UK) Fix the anchorplate into the firemans` pole (M10x30 mm screws + D.34 ext. Piece)

(S) Fäst förankringsplattan till brandmanstången (M10x30 mm screws + D.34 ext. Piece)

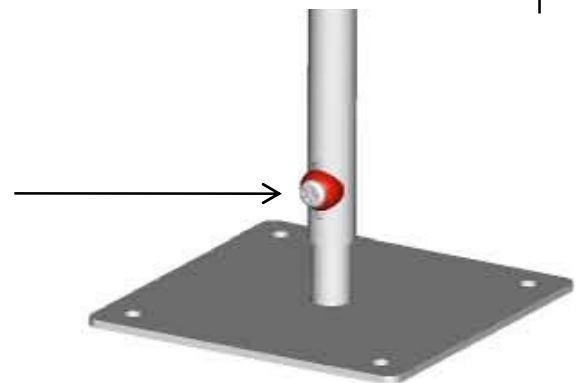

(N) Fest brannmannstangen til portalen (D.34 clamps + M10x55 screws and steel nuts)

(UK) Fasten the firemans pole onto the railing (D.34 clamps + M10x55 screws and steel nuts)

(S) Fäst brandmanstången till portalen (D.34 clamps + M10x55 screws and steel nuts)

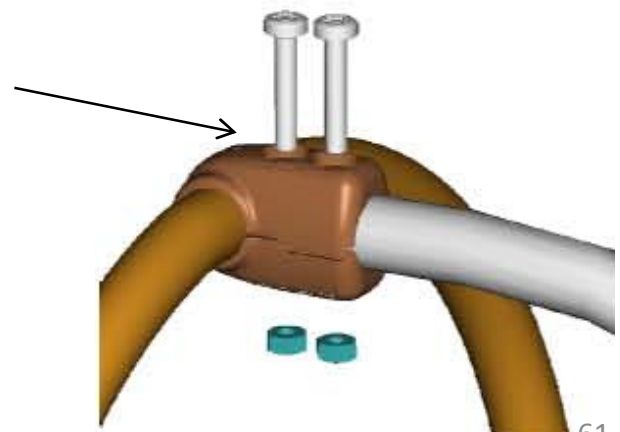

7 Montering av brannmannstang / Assembly instructions / Montering brannmannstång

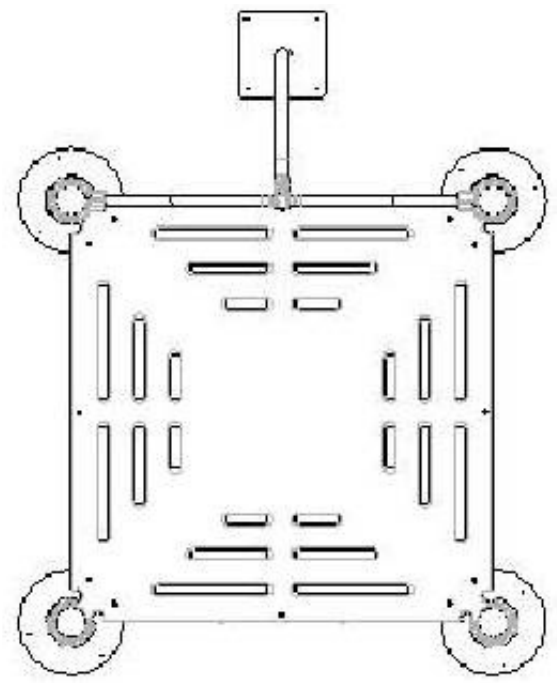
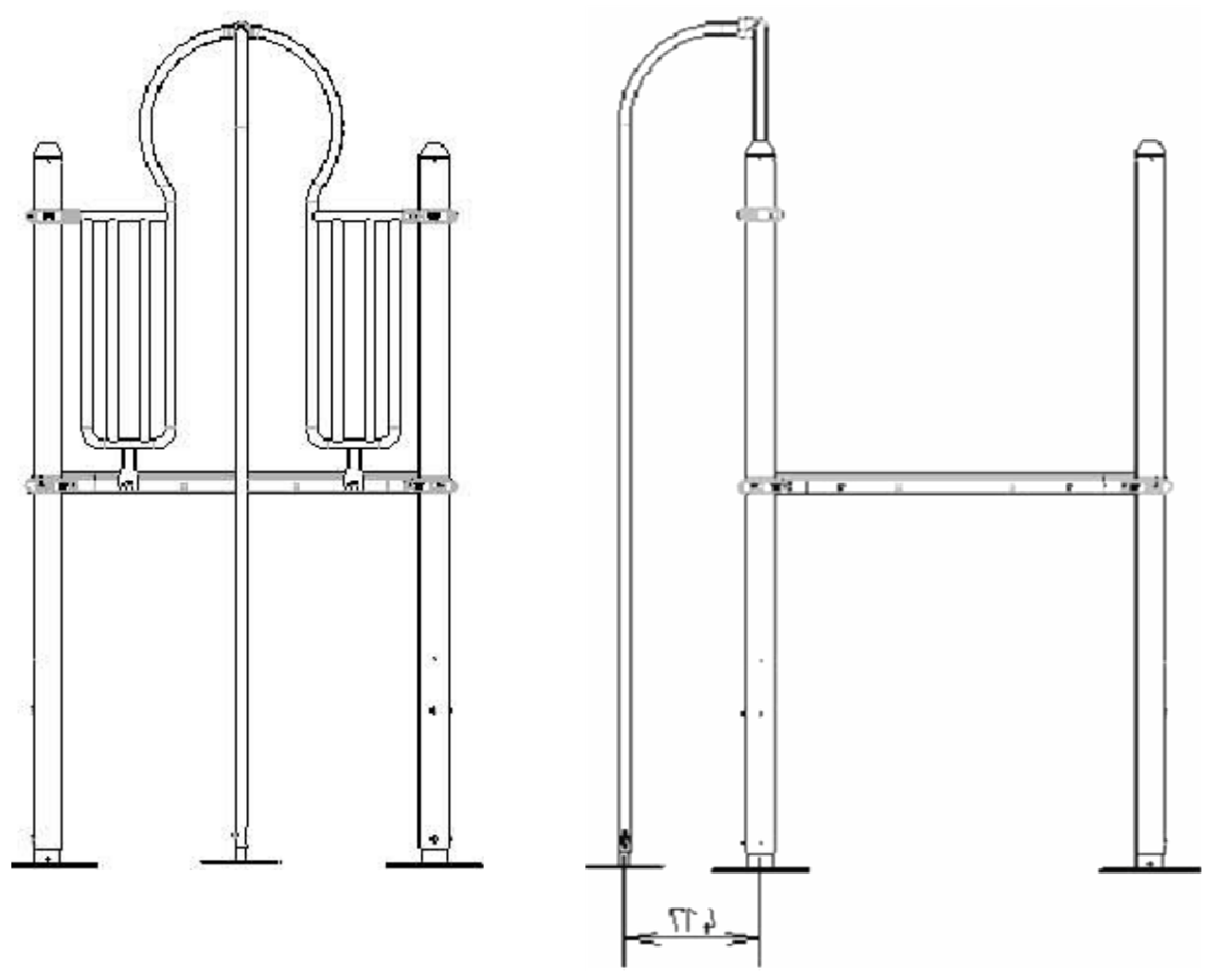

7

Montering kikkert/ Assembly instructions / Montering kikare

LIST OF PARTS:

ST.: STEEL HM10 NUT
Q00299



X2

M10x30 TORX ANTI-TAMPER SCREW Q00258



X2

PRE-ASSEMBLED CAMELEO BINOCULARS JJM-0945-EQ

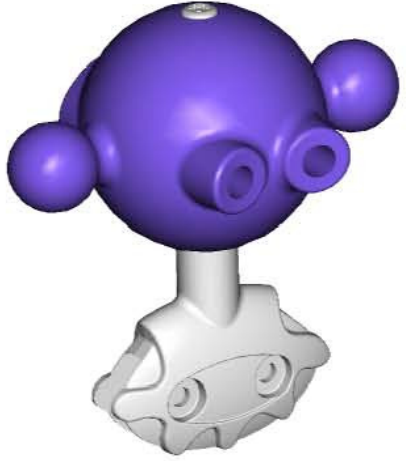

X1

INSTRUCTIONS APPLICABLE TO THE FOLLOWING PARTS
CAMELEO BINOCULARS REF JJM-0945-KI
CAMELEO MEGAPHONE REF JJM-0982-KI

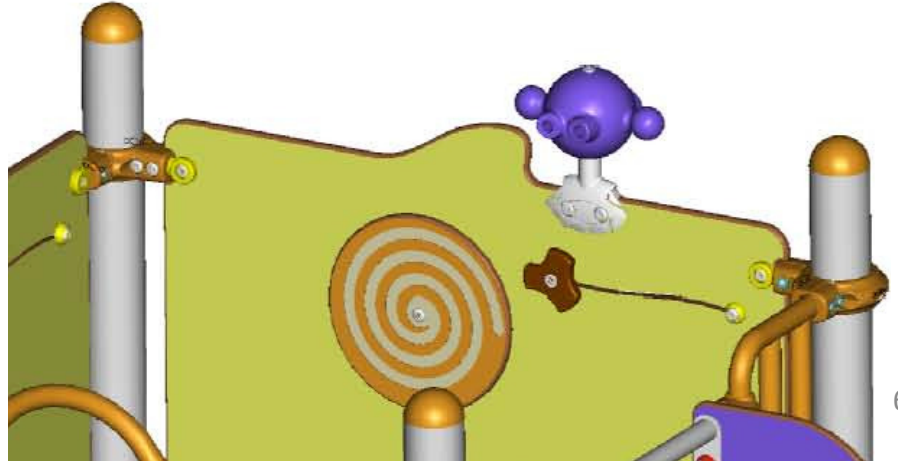
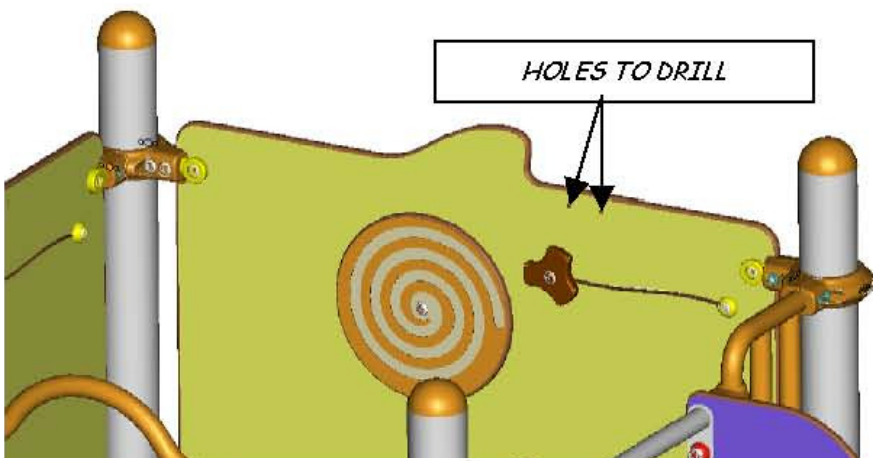

7

Montering lekebord/ Assembly instructions table/ Montering lekbord

LARGE PRE-EQUIPPED SAND TABLE
JPI-0055-EQ

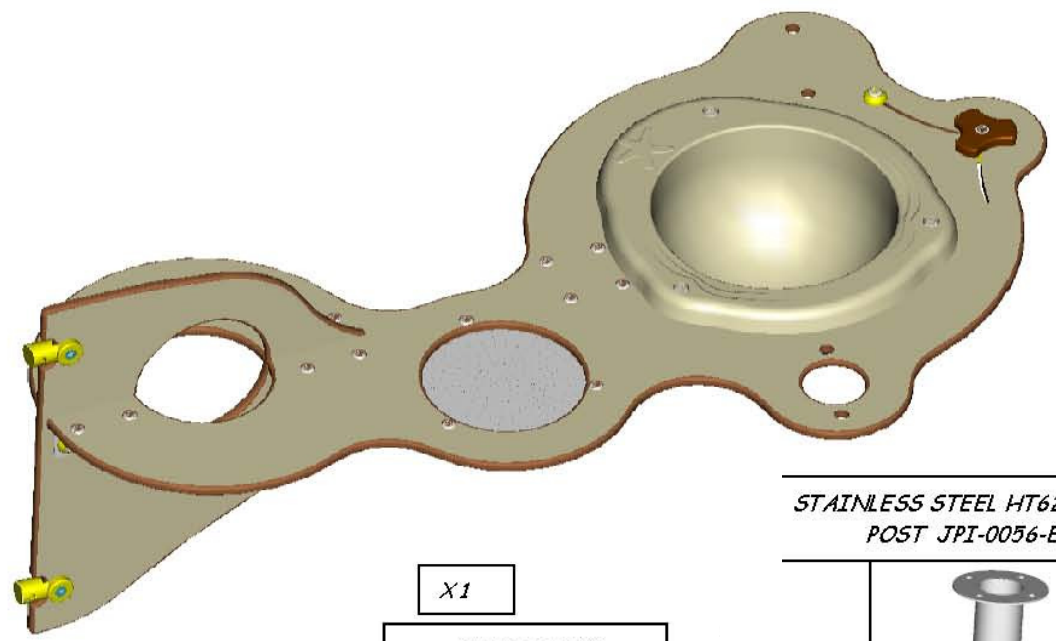

SAND TABLE SUPPORT POST L.680 LEV.0
JPI-0319-EQ

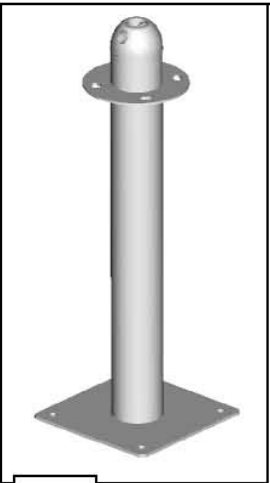

X1

X1
SEAT LEV.0
JPI-0089-00



X2

STAINLESS STEEL HT620 TABLE
POST JPI-0056-EQ

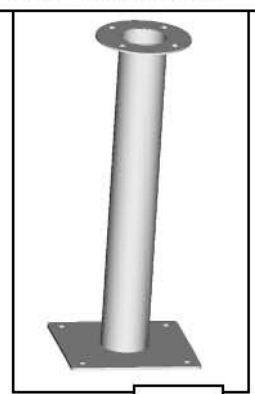

X1

SAND SHOVEL GUIDE
JPI-0318-PA

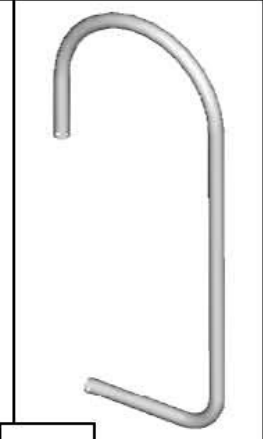

X1

PRE-EQUIPPED SAND
SHOVEL JJM-0903-EQ



X1

7

Montering lekebord/ Assembly instructions table/ Montering lekbord

LIST OF PARTS:

RED PLASTIC TORX WASHER
Q00991



X 4

ZINC-PLATED LL10N
WASHER Q00771



X 10

D.89 CLAMP WITH 1
FASTENING JJM-0081-KI



X 3

ST. STEEL HM10 NUT
Q00299



X 2

M10x55 TORX ANTI-
TAMPER SCREW Q00259



X 1

STAINLESS STEEL M10 TORX ANTI-
TAMPER CAP NUT Q00261



X 4

M10x16 TORX ANTI-TAMPER
SCREW Q00260



X 4

7 Montering lekebord/ Assembly instructions table/ Montering lekbord

(N) Fest stolpene til sandbordet
(M10x16 screws + torx cap nuts +
LL10N washers + red plastic torx washers

(UK) Fit the posts onto the pre-equipped sand table
(M10x16 screws + torx cap nuts + LL10N washers
+ red plastic torx washers

(S) Fäst stolparna till sandbordet
(M10x16 screws + torx cap nuts +
LL10N washers + red plastic torx washers

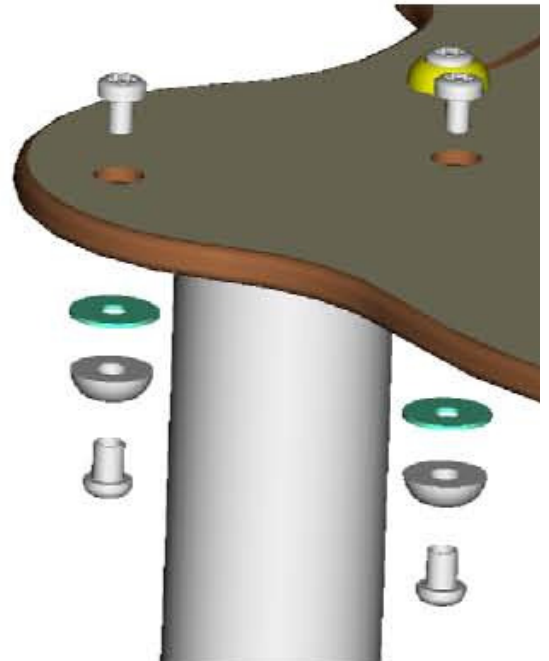

(N) Fest stolpen for sandskuffa
(M10x55 screw +M10 nut + D.89 clamp)
Husk å tre i kjettingen for skuffa i på røret først

(UK) Fit the sand shovel guide
(M10x55 screw +M10 nut + D.89 clamp)
Do not forget to slip on the
chain of the shovel first

(S) Fäst stolpen för sandgrävaren
(M10x55 screw +M10 nut + D.89 clamp)
Kom ihåg att sätta i kedjan till grävskopan först

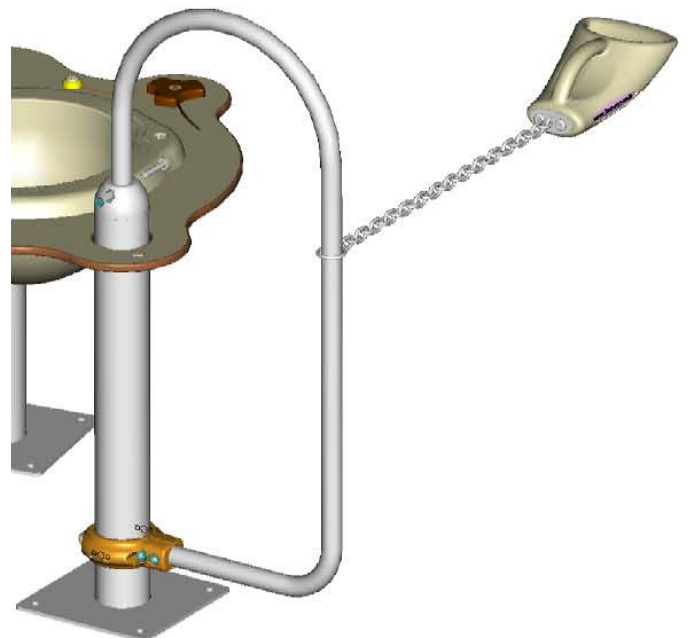

7 Montering lekebord/ Assembly instructions table/ Montering lekbord

(N) Fest bordet til stolpen på det lille huset i riktig retning (D.89. clamps)
Plasser bordet iht forankringsplanen

(UK) Fit the pre-assembled assembly to the equipment frame,
ensuring it is the right way round (D. 89. clamps)

Position and fasten the seats in the positions shown in the layout drawing

(S) Fäst bordet till stolpen av den lilla stugan i rätt riktning (D.89. clamps)
Placera bordet enligt förankringsöversikten

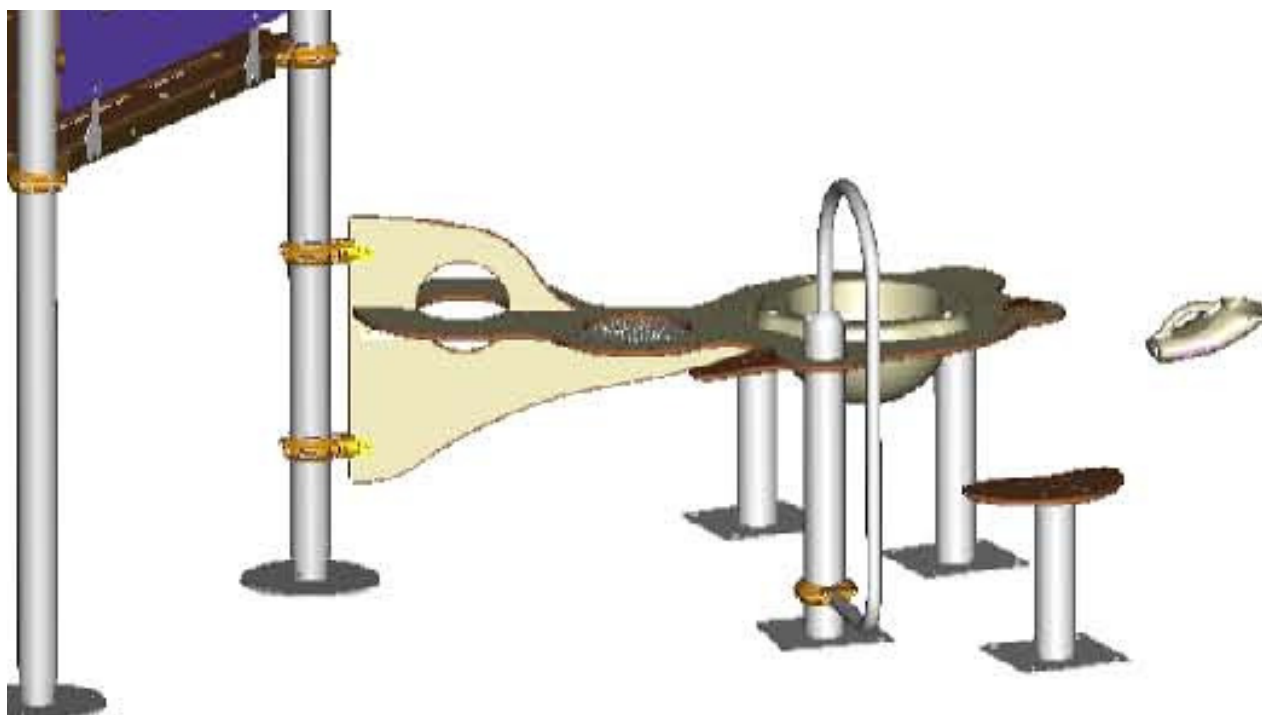

7 Montering lekebord/ Assembly instructions table/ Montering lekbord

ASSEMBLY:

- 1) Fit the posts onto the pre-equipped sand table (M10x16 screws + torx cap nuts+ LL10N washers + red plastic torx washers)
- 2) Fit the sand shovel guide (M10x55 screw + M10 nut + D.89 clamp)
Do not forget to slip on the chain of the shovel first

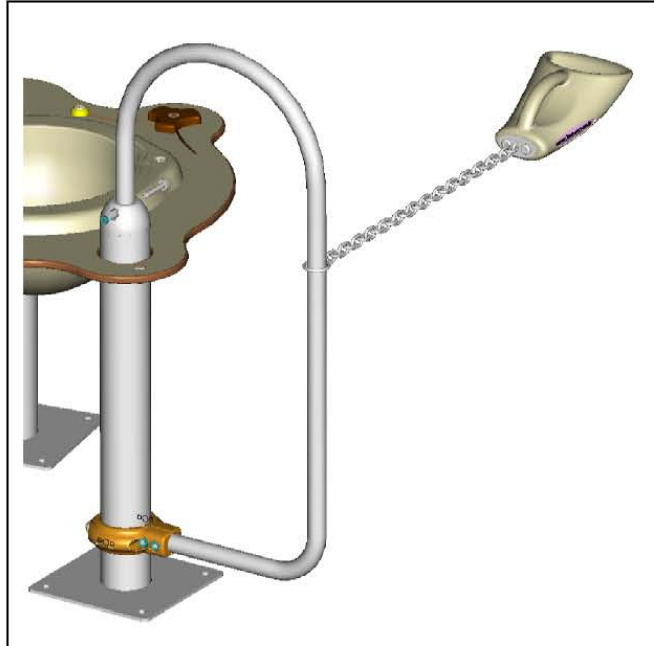
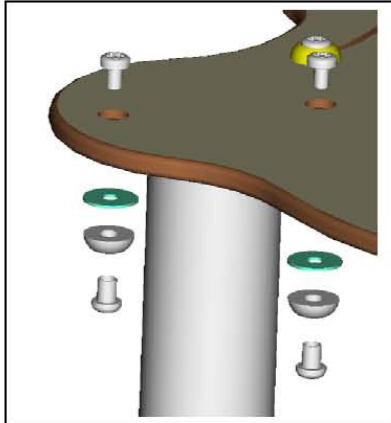

- 3) Fit the pre-assembled assembly to the equipment frame, ensuring it is the right way round. (D.89 clamps)
- 4) Position and fasten the seats in the positions shown in the layout drawing

