

**(N) Monteringsanvisning**

**(UK) Assembly Instructions**

**(S) Monteringsanvisning**

Produkt nr. / Product no. / Produkt nr.

**70-870-010**  
**15 x 24 m**

Ordr. nr. \_\_\_\_\_

Dato. \_\_\_\_\_

Sign. \_\_\_\_\_

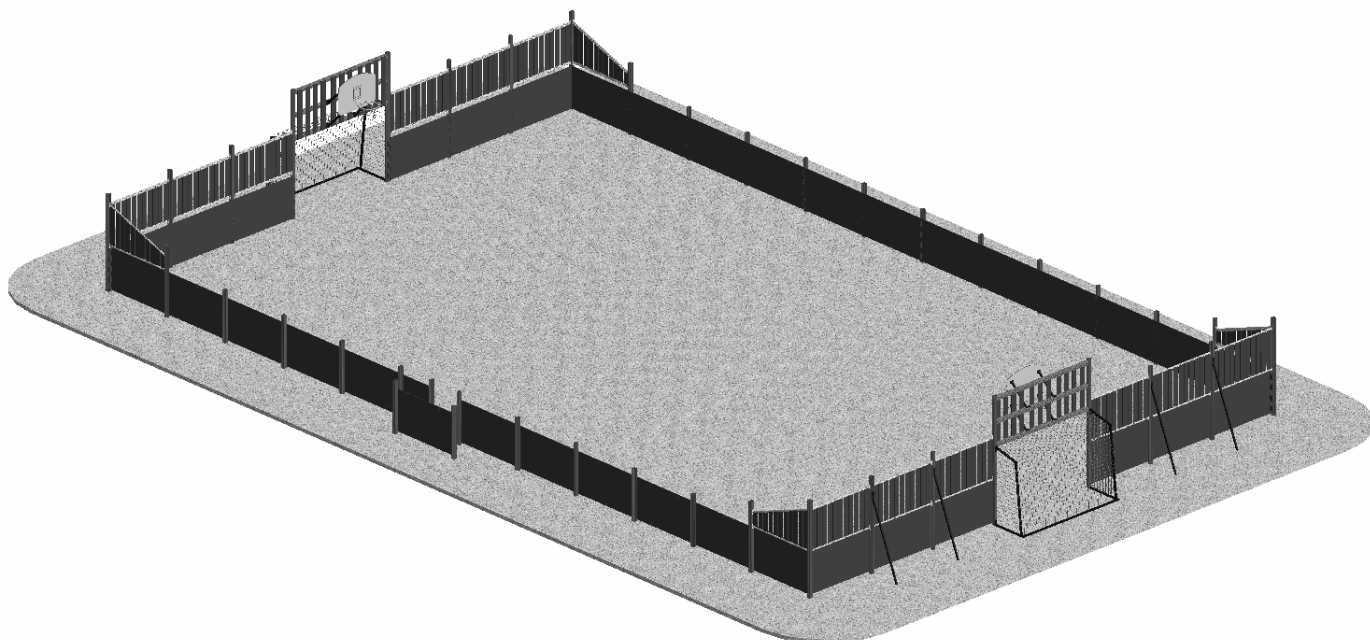

**Søve Lekemiljø AS**  
3830 Ulefoss - Norway  
Tlf: +47 35 94 65 65  
[www.sove.no](http://www.sove.no)



**Søve AB**  
Göteborg  
Phone: +46 (0)31 773 97 00  
[www.sove.se](http://www.sove.se)

27.05.2010

1

## Monteringstips / Assembly Advice / Monteringsstips

N

3 Les monteringsanvisningen nøye før montering.

3 Monter elementene i rekkefølgen som vist.

3 Boltene bør ikke skrues for hardt til før alt er montert, vatret og loddet. Skru så boltene til.

NB! Ved bruk av drill, kan boltene ryke.

3 På grunn av at solen kan gjøre rutsjeflaten veldig varm, bør rutsjebanens utløp vende mot nord-øst eller nord-vest.

3 Er lekeutstyret plassert i naturlige ferdselstraséer må området sikres mot spontan gjennomgang.

3 Innspringningshinder bør vurderes rundt lekeapparater hvor det er stor bevegelse, f.eks. ved huskestativ.

3 Det bør være fritt innsyn til lekeutstyr som er beregnet for barn under 3 år.

**NB! Under monteringsarbeidet må utstyr, som ikke er forankret forsvarlig i bakken, avstives slik at det ikke velte.**

**Området må avstenges under oppsettelse av apparatene med sperrebånd eller lignende.**

UK

3 Read the instruction carefully before assembling the play unit.

3 Assemble the components in the sequence shown in these instructions.

3 Fixings must not be fully tightened during assembly. Before casting the foundations, the structure must be level and plumb, at which point all fixings are tightened.

PS! If use of drill, the bolts may be wrecked.

3 Avoid positioning the slide facing due south because of overheating – ideal positions are facing north-east or north-west.

3 Secure the construction-area to prevent people from walking through it.

3 Consider installing barriers around play-equipment which gives rise to a lot of activity – i.e. swings.

3 Ensure that clear vision is possible across the play area so that supervision is possible from any position, particularly where children under 3 years of age will be playing.

**NB! During assembly of the equipment, ensure that all structures are securely propped, especially when left overnight. Also ensure that equipment is supported whilst concrete foundations are setting and enclose the area securely to prevent access.**

S

3 Läs monteringsanvisningen noga före montering.

3 Montera delarna i den ordningen som anvisas

3 Skruvarna bör inte skruvas för hårt tills allt är monterat, i våg och lodat.

OBS! Används elektrisk skruvdragare, kan bulten gå sönder. Hårdra därför manuellt!

3 Solen kan göra att rutchbanan blir väldigt varm. Banans nedfart rekommenderas att vändas i norrlig riktning

3 Om lekplatsen placeras vid en gångväg mm bör området säkras mot genomfart av gående och cyklister.

3 Inspiringningshinder bör placeras runt lekutrustning med stor rörelse, t ex, gungställning.

3 Det bör vara fri insyn till lekutrustning beräknat till barn under 3 år.









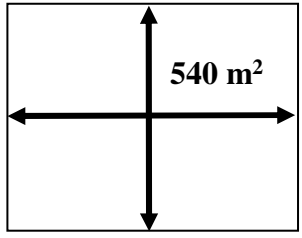

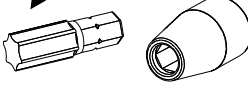

**OBS! Under monteringsarbete bör utrustningen som inte ska förankras i marken, ställs så att den inte kan välta.**

**Området måste spärras när lekutrustningen byggs upp, med avspärrningsband eller liknande.**

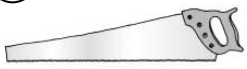
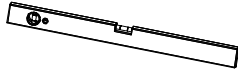
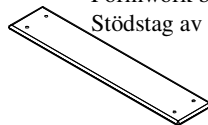
2	<b>Nødvendig verktøy / Tools required / Nödvändiga verktyg</b>				
N	<b>A</b> 	<b>B</b>  Torx Nr 45 High quality 	<b>C</b>  13 mm 17 mm 	<b>D</b> 	<b>E</b> 
UK	<b>F</b> 	<b>G</b> Metermål Metric measure Tumstock 	<b>H</b> 18V 	<b>I</b> Merkebånd Mark ribbon Märkeband 	<b>J</b> 5 mm 

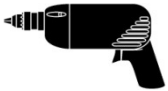
3	<b>Nødvendig antall personer / Number of persons required / Lämpligt antal personer</b>					
N UK S						

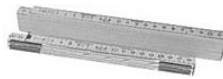
4	<b>Anbefalt arealbehov ved montering / Recommended working space / Rekommenderad arealbehov vid montering</b>					
N UK S						

<p><b>2</b></p> <p>N UK S</p>	<p><b>Nødvendig verktøy / Tools required / Nödvändiga verktyg</b></p>				
	<p><b>A</b></p> 	<p><b>B</b></p>  <p>Torx Nr 45 High quality</p> 	<p><b>C</b></p>  <p>13 mm 17 mm</p> 	<p><b>D</b></p> 	<p><b>E</b></p> 
<p><b>G</b></p> 	<p><b>I</b></p> <p>Forskalingsbord Formwork boards Stödstag av trä</p> 	<p><b>K</b></p> 	<p><b>L</b></p> <p>Merkebånd Mark ribbon Märkeband</p> 	<p><b>M</b></p> 	<p><b>N</b></p>  <p>5 mm</p>
<p><b>H</b></p> <p>Metermål Metric measure Tumstock</p> 	<p><b>J</b></p> 				

<p><b>3</b></p> <p>N UK S</p>	<p><b>Nødvendig antall personer / Number of persons required / Lämpligt antal personer</b></p>					
						

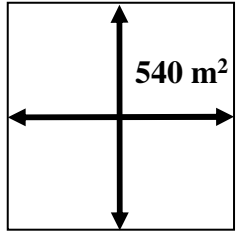





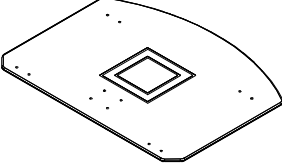
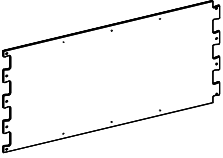

<p><b>4</b></p> <p>N UK S</p>	<p><b>Anbefalt arealbehov ved montering / Recommended working space / Rekommenderad arealbehov vid montering</b></p>
	

5

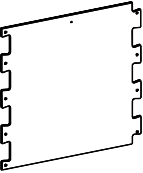
Pakkliste for / Parts list for / Packlista för :  
70-870-010

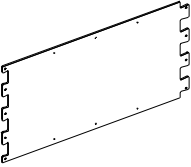
1 av 3

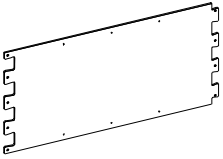
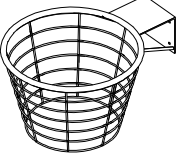
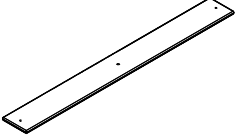

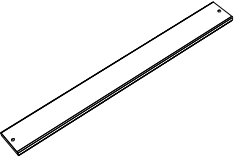
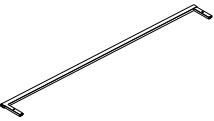
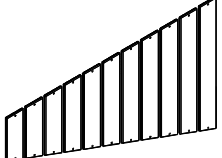
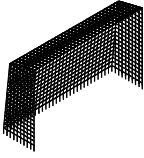







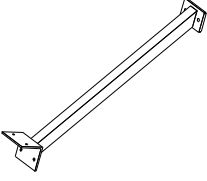
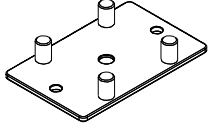

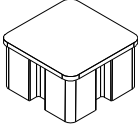
Sign. \_\_\_\_\_

(N) (UK) (S)	Komponenter	Dimensjon	Ant	Lev	Komponenter	Dimensjon	Ant	Lev
	Components	Dimension	Qty	Lev	Components	Dimension	Qty	Lev
	Komponenter	Dimension	Ant	Lev	Komponenter	Dimension	Ant	Lev
		4145 x 95x 95 3180 x 95x 95 NB!Hjørnestolper 2990 x 95x 95 2500 x 95x 95 2000 x 95x 95	4 12 (4) 6 4 21			1200 x 900 x 15	2	
		1100 x 2064 x 15	28			1905 x 120 x 40	28	
		1100 x 1064 x 15	1			2070 x 120 x 40	2	
		1100 x 2064 x 15	4			2070 x 120 x 40	2	
		1100 x 2064 x 15	4			640 x 160	2	
		1280 x 150 x 15	22			2143 x 893 x 40	4	
		1022 x 150 x 15	132			3159 x 310 x 30	2	
		(N) 4 av hver (UK) 4 of each (S) 4 av hvarje	4				2	

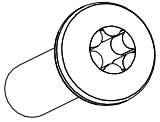
**5****Pakkliste for / Parts list for / Packlista för :  
70-870-010**

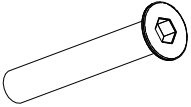
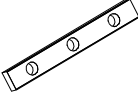
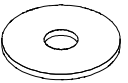
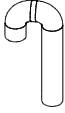
2 av 3

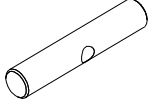
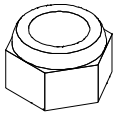
Sign. \_\_\_\_\_













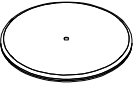

	Komponenter Components Komponenter	Dimensjon Dimension Dimension	Ant Qty Ant	Lev Lev	Komponenter Components Komponenter	Dimensjon Dimension Dimension	Ant Qty Ant	Lev Lev
		770 x 120 x 120	8				150 x 95 x 25	12
	2996 x 70	4				55 x 95 x 95	41	
	4940 x 70	4			 Produkt merking Product marking Produkt märkning		1	
	Bolter/skruer Bolts/Screws Komponenter	Dimensjon Dimension Dimension	Ant Qty Ant	Lev Lev	Bolter/skruer Bolts/Screws Bultar/Skruvar	Dimensjon Dimension Dimension	Ant Qty Ant	Lev Lev
	04-000-012 8 x 12 mm Torx 04-000-016 8 x 16 mm Torx 04-000-025 8 x 25 mm Torx 04-000-030 8 x 30 mm Torx 04-000-035 8 x 35 mm Torx	8 376 128 48 399				04-060-040 40 x 15 x 8 mm	70	
	04-150-060 10 x 60 mm	12				04-060-120 120 x 15 x 8 mm 04-060-160 160 x 15 x 8 mm	88 16	
	04-050-008 8 mm 04-055-010 10 mm	8 8				04-009-025 8 x 25 mm	50	
	04-030-016 8 x 16 mm	376				04-018-095 18 x 95 mm	12	
	04-040-010 10 mm	4				04-010-055 10 x 55 mm	4	
						<b>Skruesikring</b>	1	

**5****Pakkliste for / Parts list for / Packlista för :  
11-145-150**

3 av 3

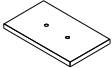
Sign. \_\_\_\_\_

**Forankring / Foundations / Markförankring****00-003-003**

 00-003-100  00-003-101  00-003-102							04-000-035 8 x 35 mm Torx	<b>123</b>	
							04-050-008 8 mm	<b>123</b>	
							04-060-120 120 x 15 x 8 mm	<b>82</b>	
00-003-103 							04-000-040 8 x 40 mm Torx	<b>0</b>	
							04-040-008 8 mm	<b>0</b>	
							04-050-008 8 mm	<b>0</b>	
Eller Or Eller 00-003-105  00-003-106 							04-010-035 10 x 35 mm	<b>24</b>	
							04-040-010 10 mm	<b>24</b>	
							04-050-010 10 mm	<b>24</b>	

**41****12**



6

Fundamentering / Foundation / Förankring



- (N) For stolper
- (UK) For posts
- (S) För stulpar

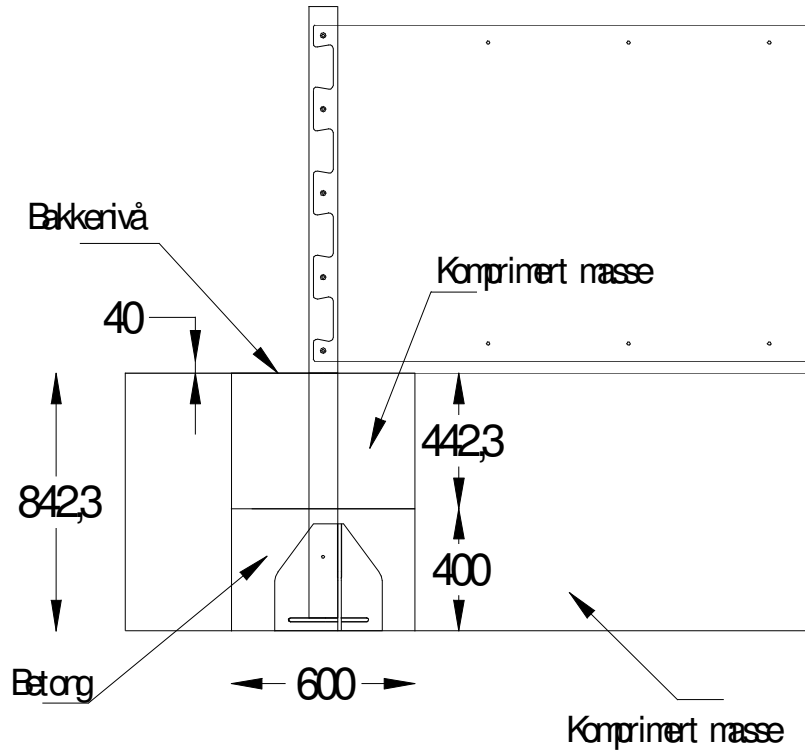

- (N) Komprimert masse
- (UK) Compressed mass
- (S) Komprimerad masse

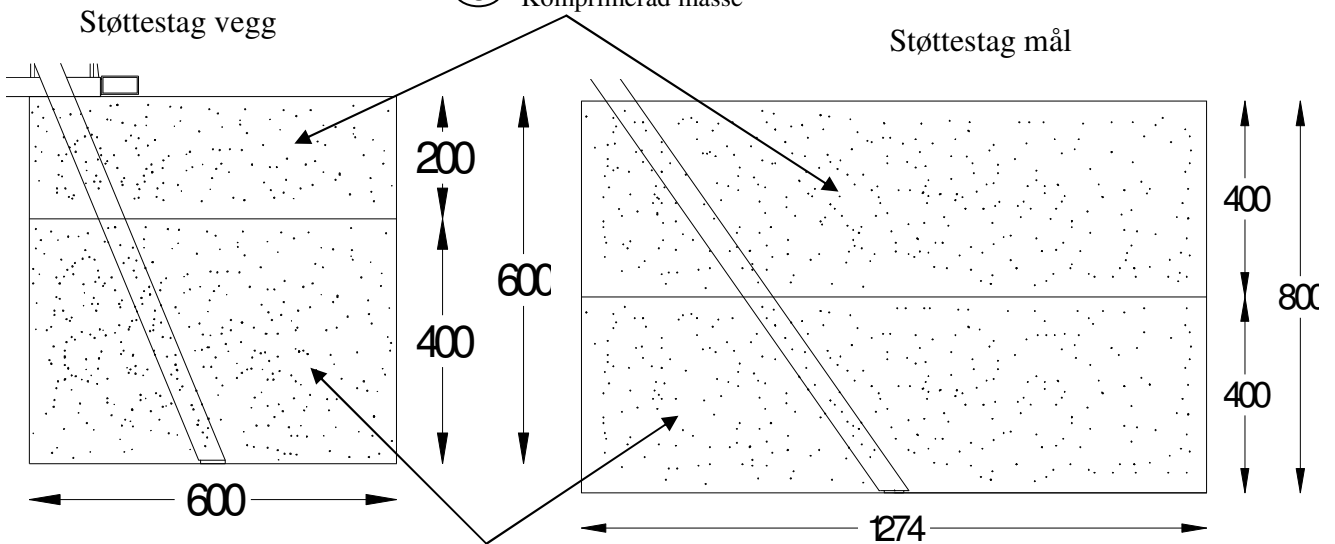

- (N) Betong
- (UK) Concrete
- (S) Betong

- (N) Alle mål er oppgitt i millimeter
- (UK) Scale measured in mm
- (S) Alla mått är i millimeter.

6

# Plassering av forankringer / Ground plan / Placering av förankringar

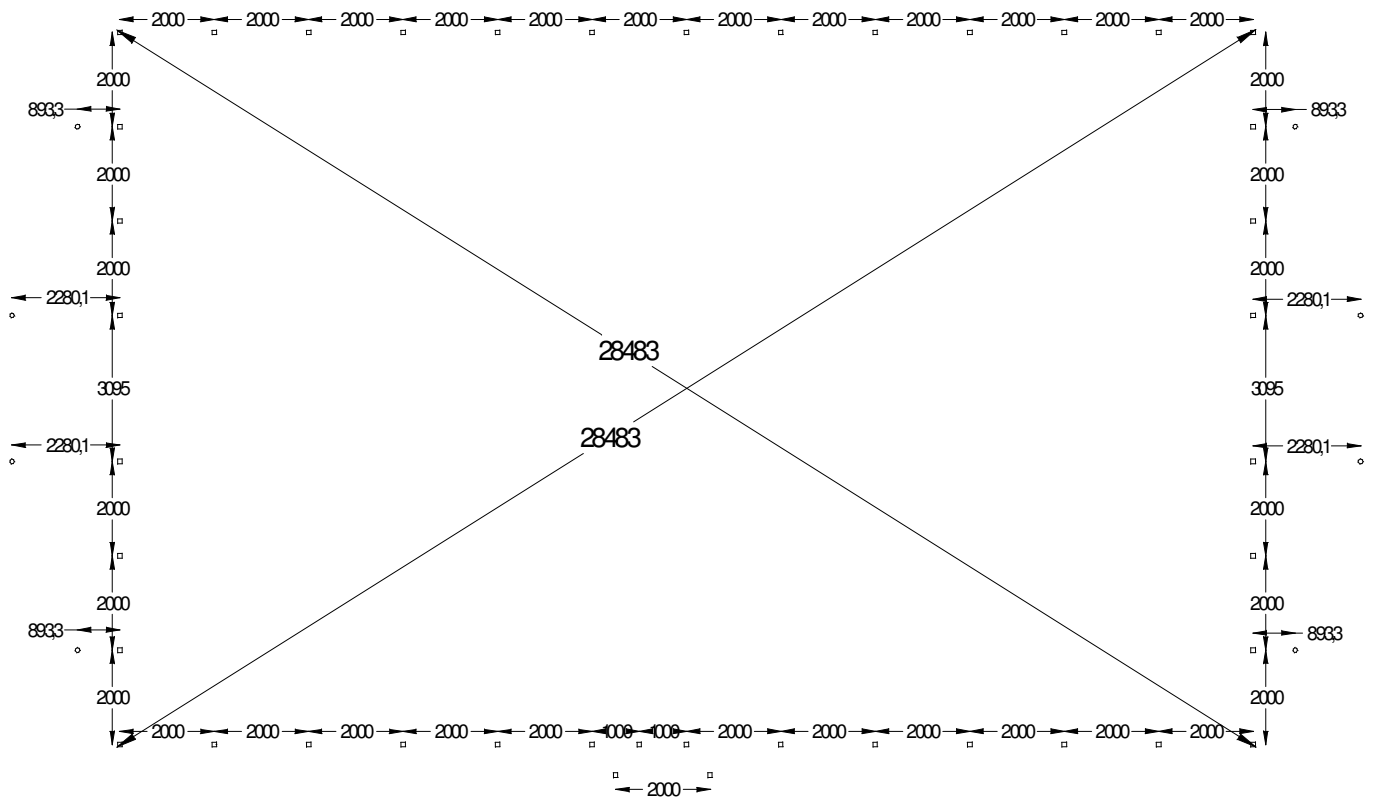

- (N) Alle mål er oppgitt i millimeter
- (UK) Scale measured in mm
- (S) Alla mått är i millimeter.

**OBS !**

- Ⓝ Bolter skrues helt igjennom aluminiumstolpene. Om elektrisk drill brukes anbefales 18 V
- Ⓚ Bolts must be tightened through the post, so that it pierces the aluminium.
- Ⓢ Bultarna skruvas rakt igenom aluminiumstolparna. Om elektrisk skruvdragare används rekommenderas 18 V

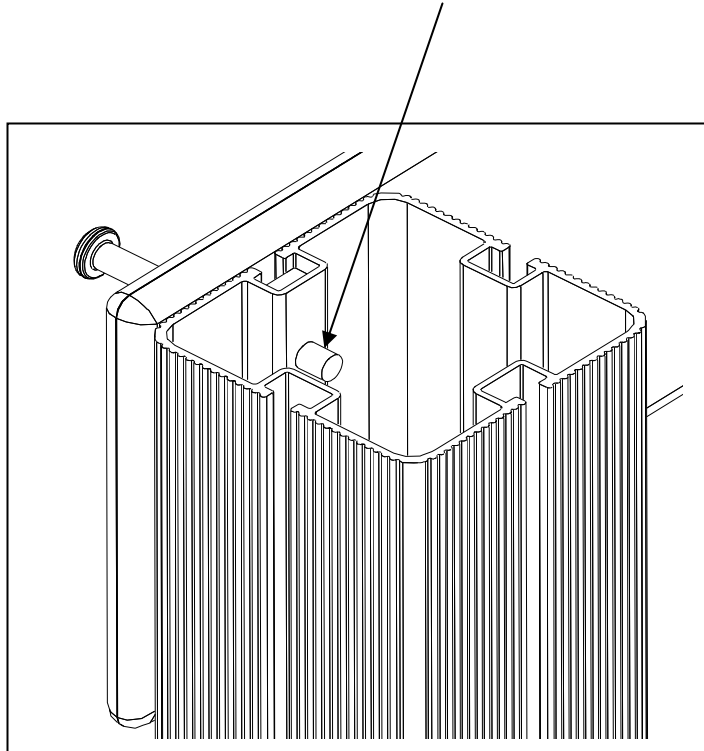

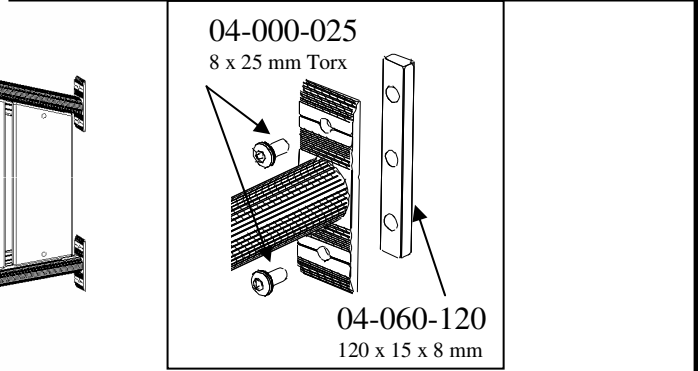
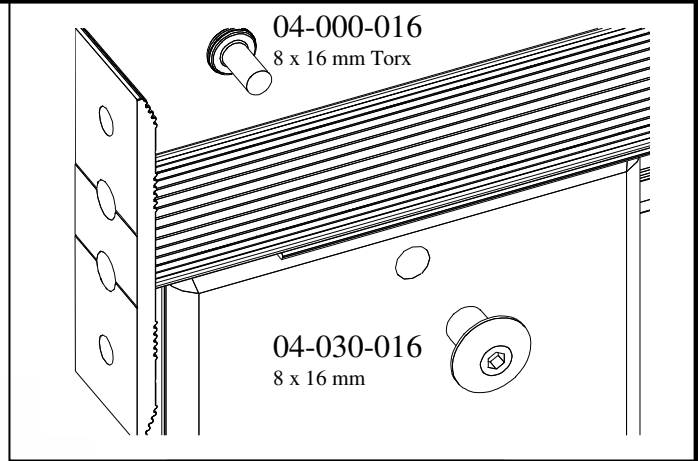
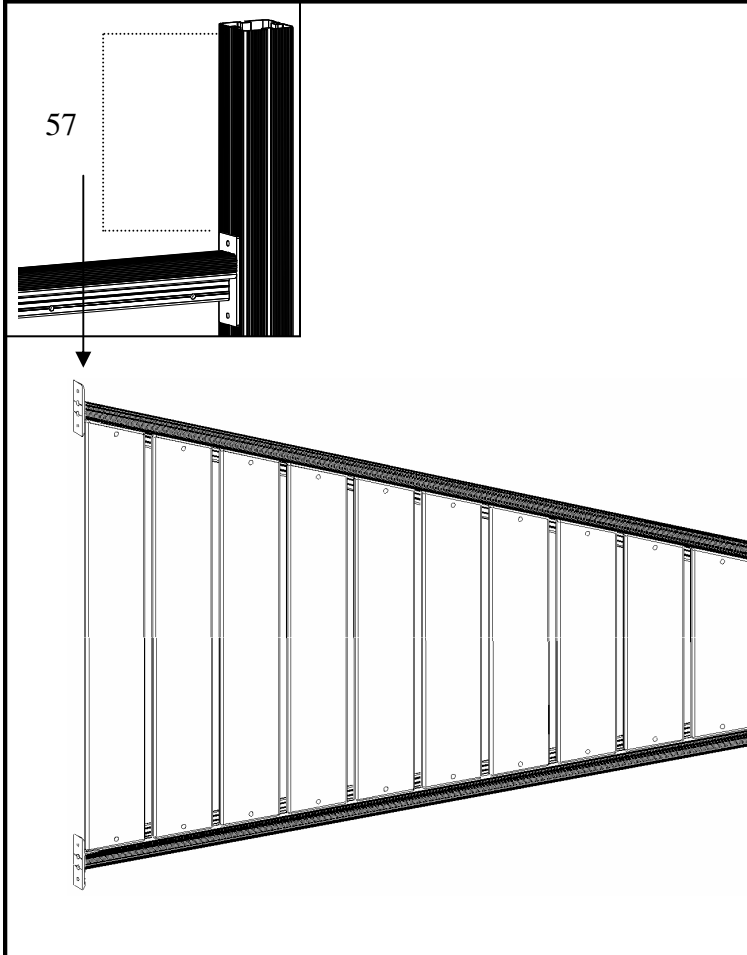
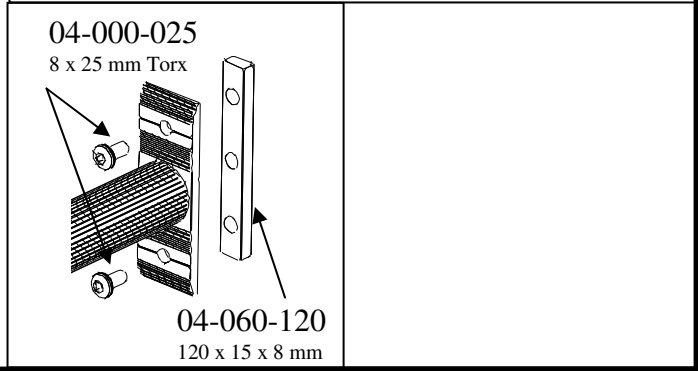
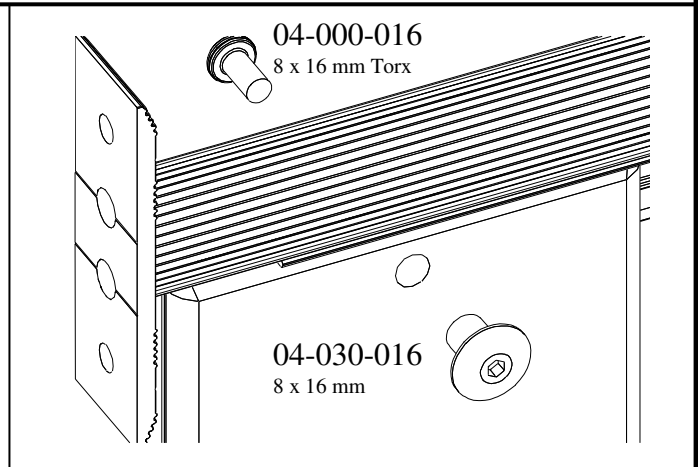
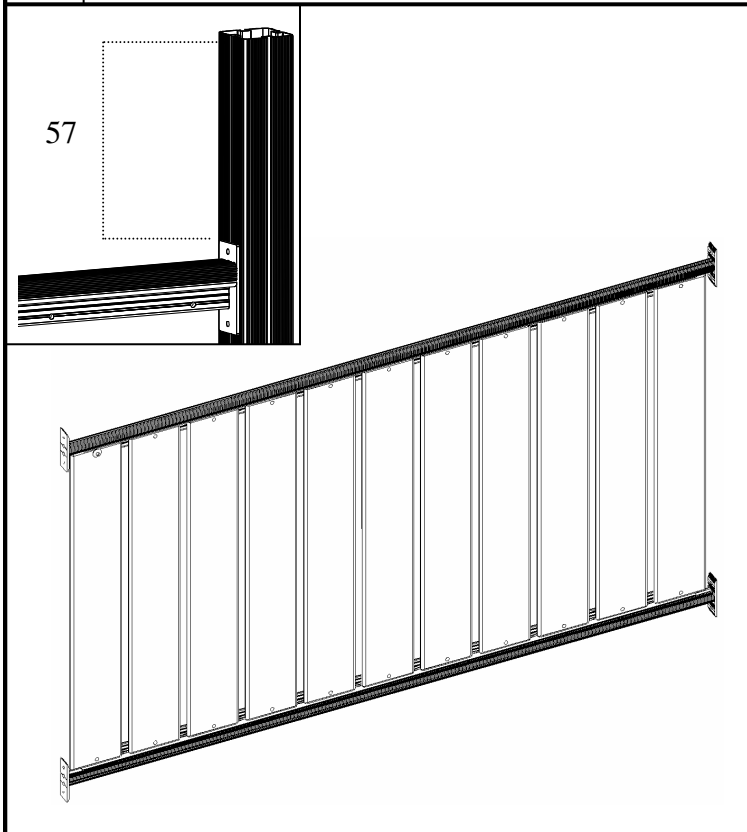

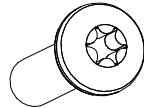
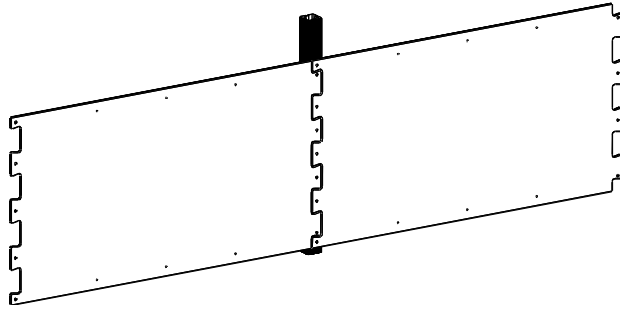
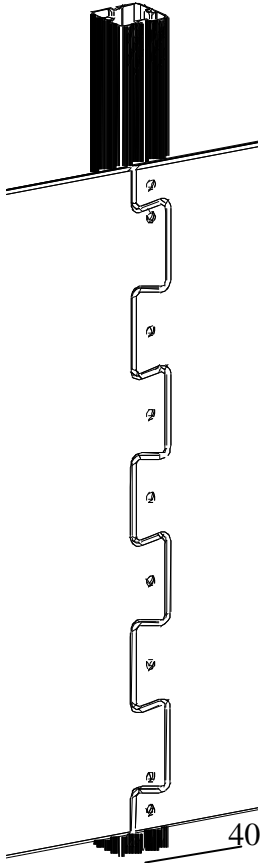

04-000-035  
8 x 35 mm Torx

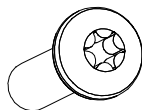
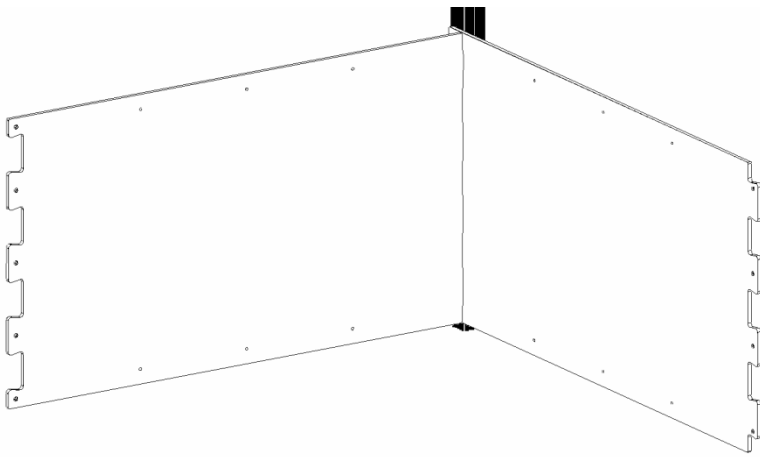
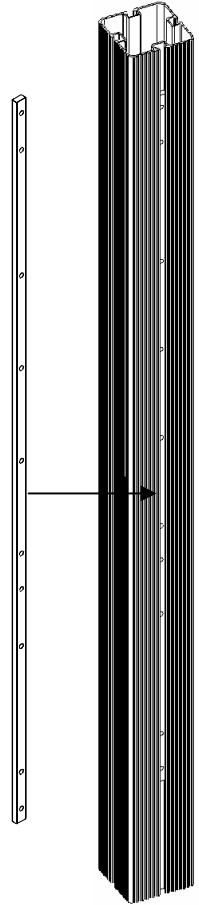

04-000-035  
8 x 35 mm Torx

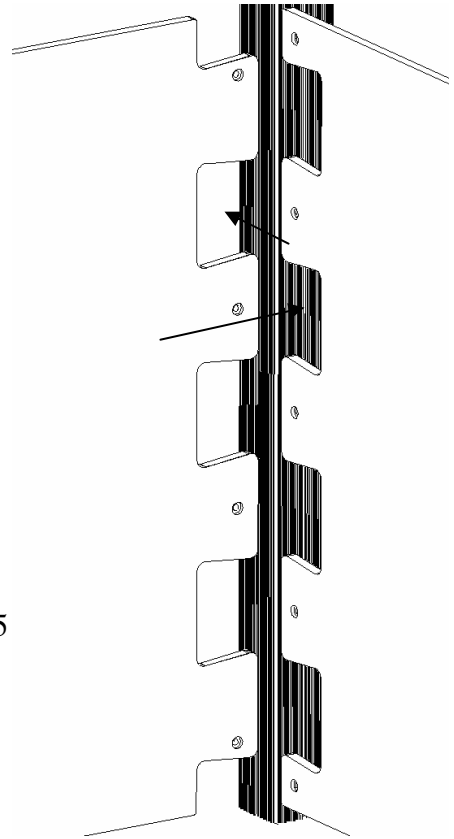

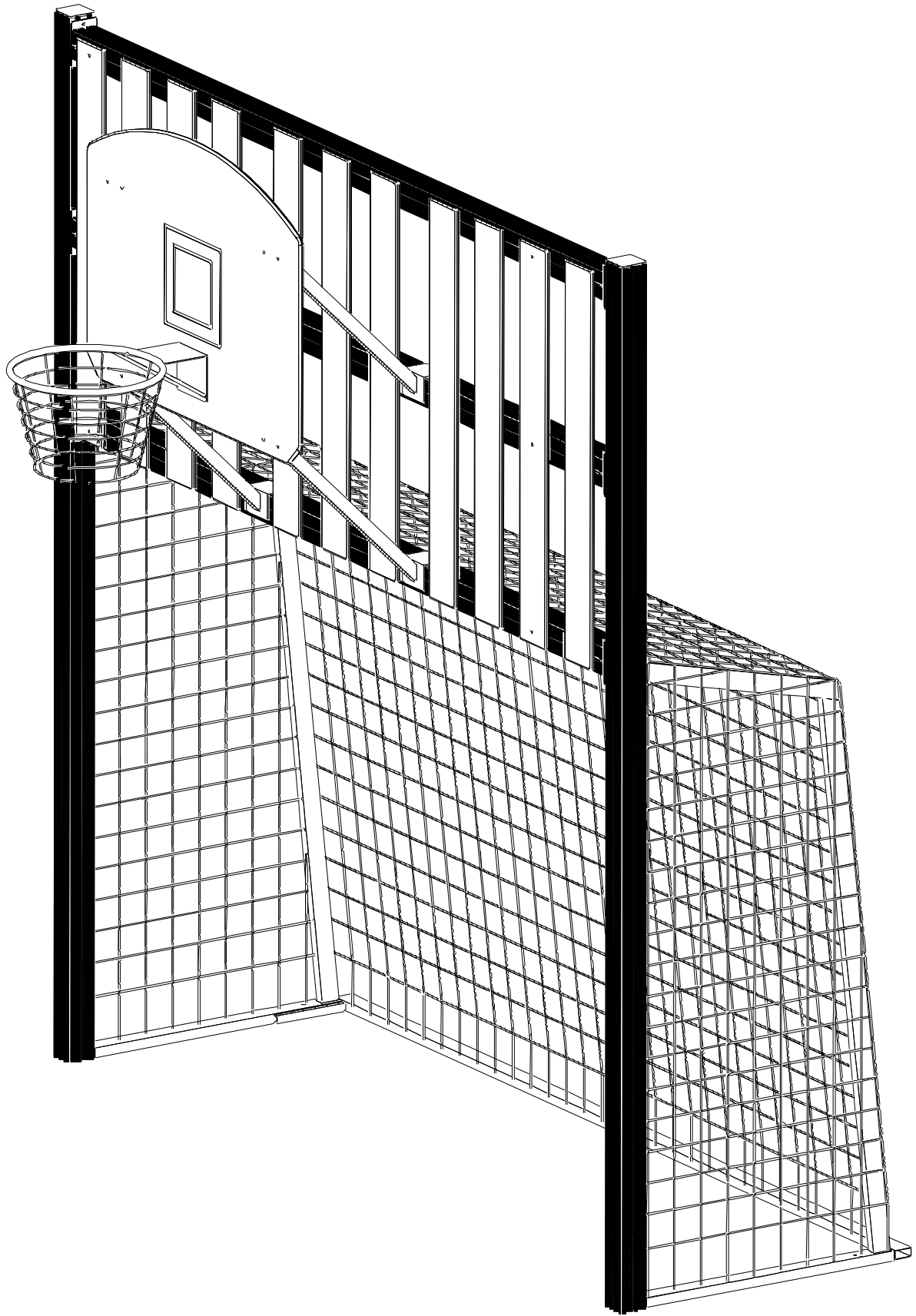

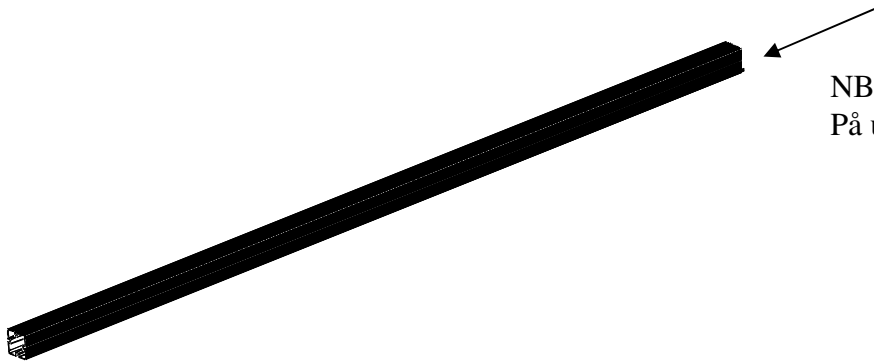
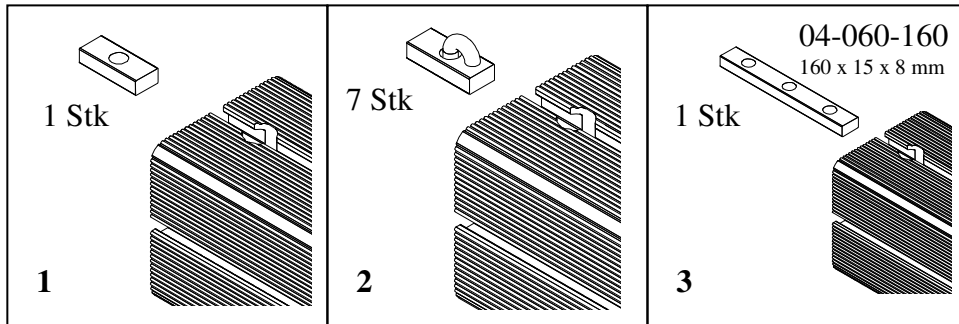
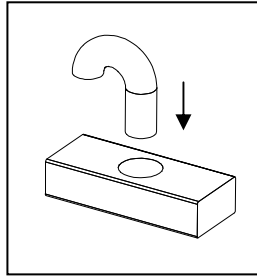

NB!!  
På undersiden

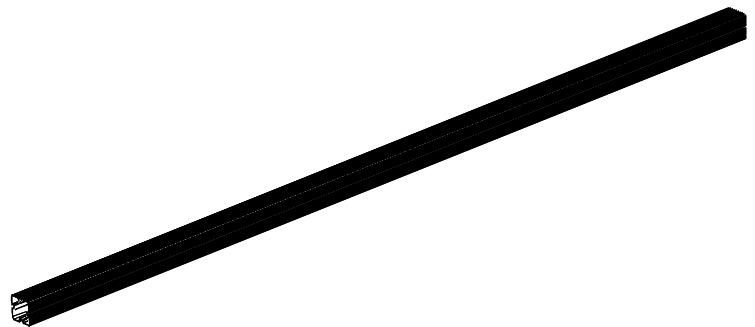

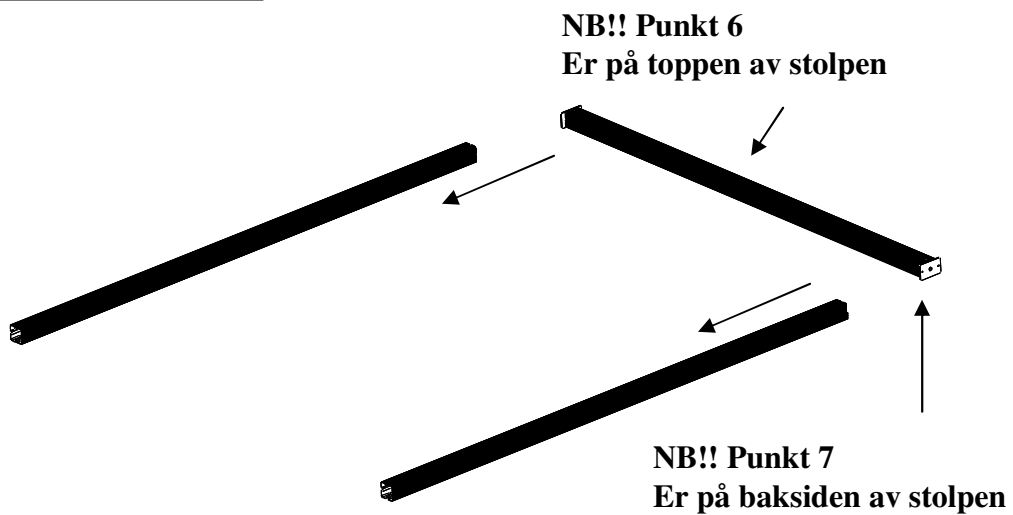
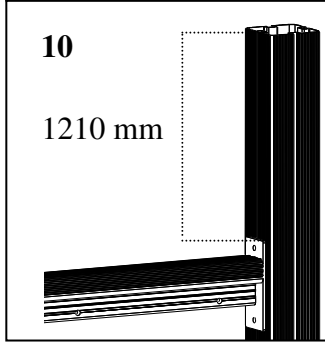
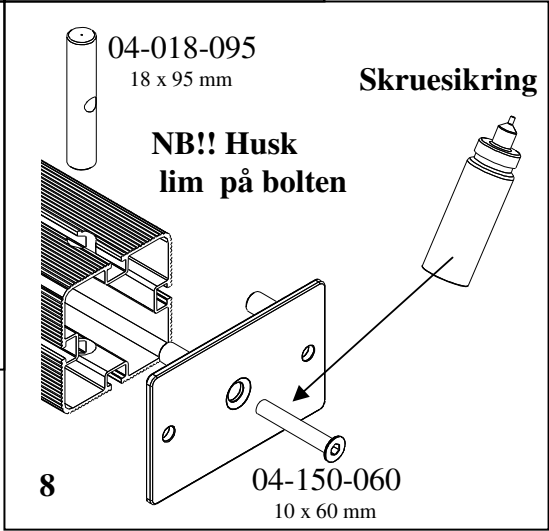
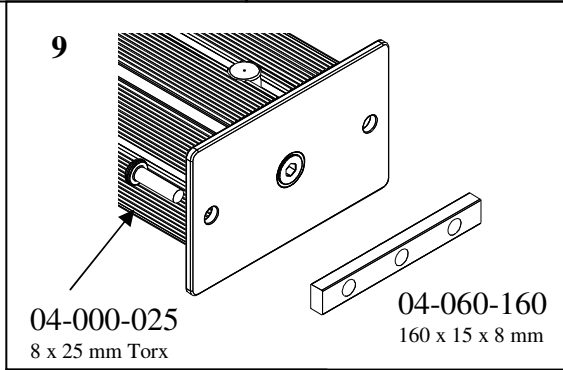
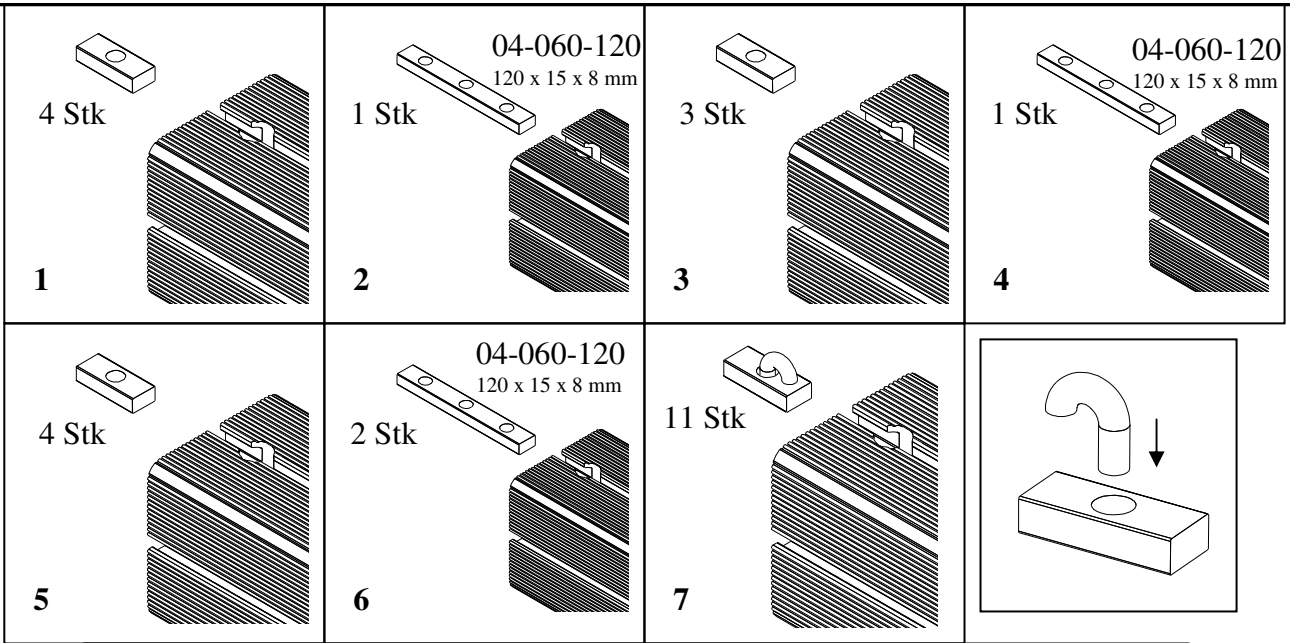



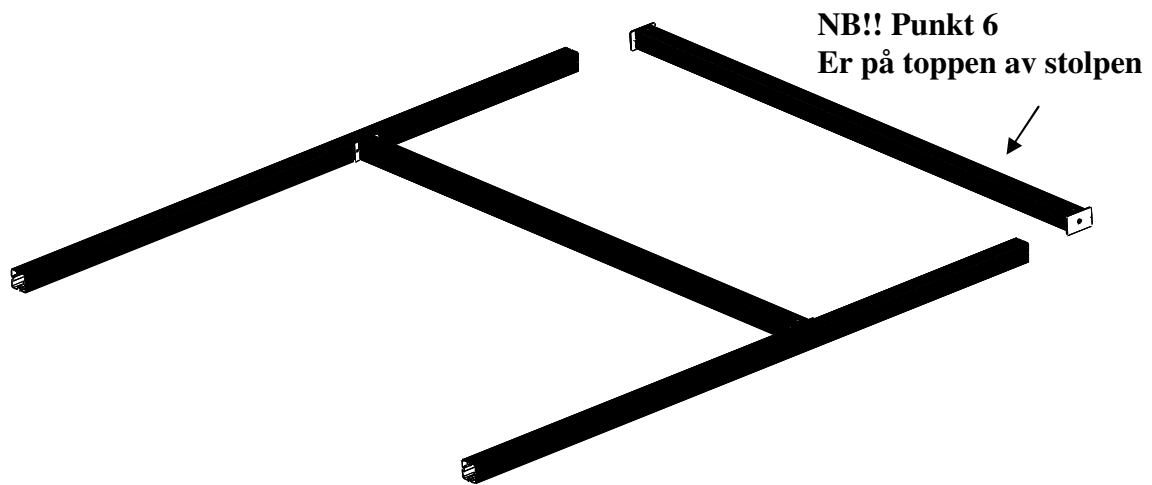
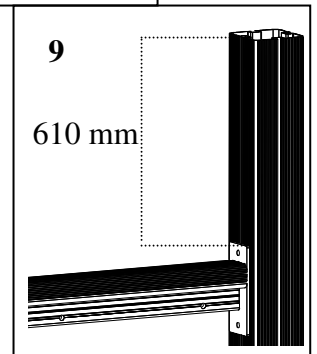
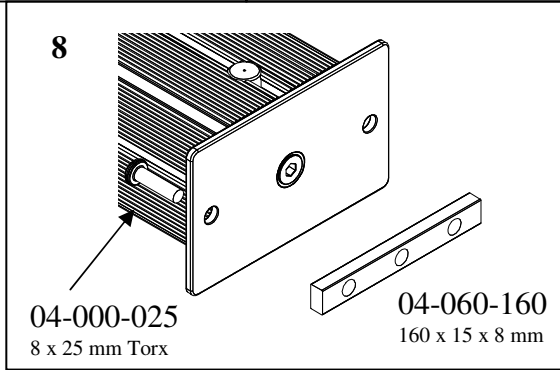
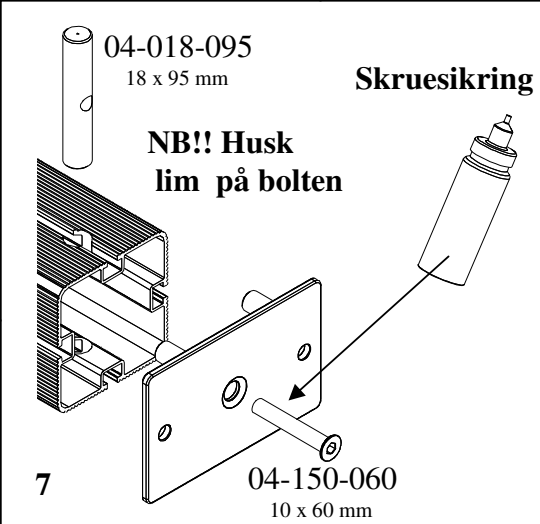
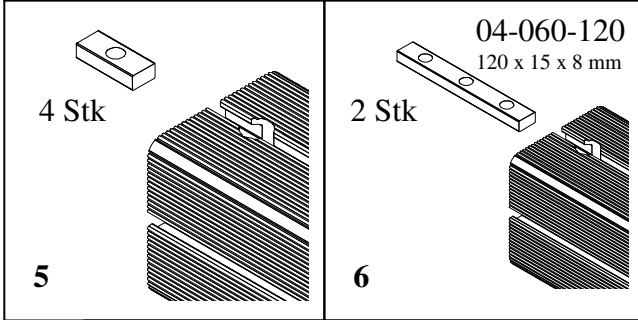
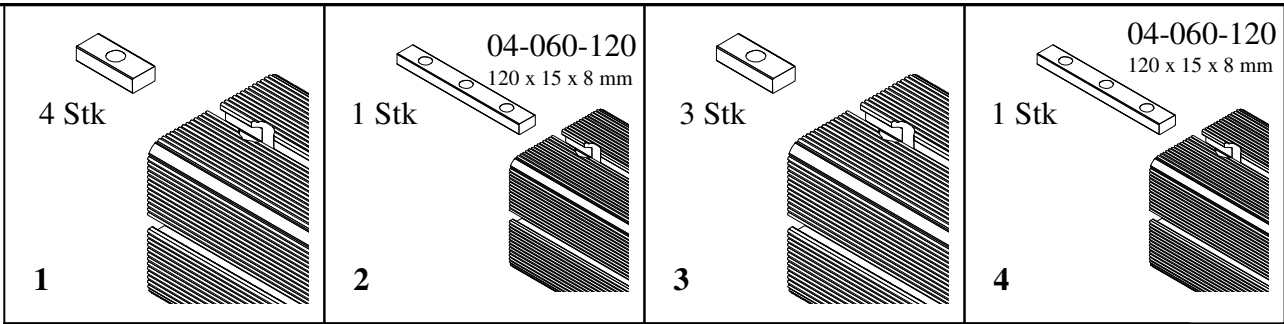

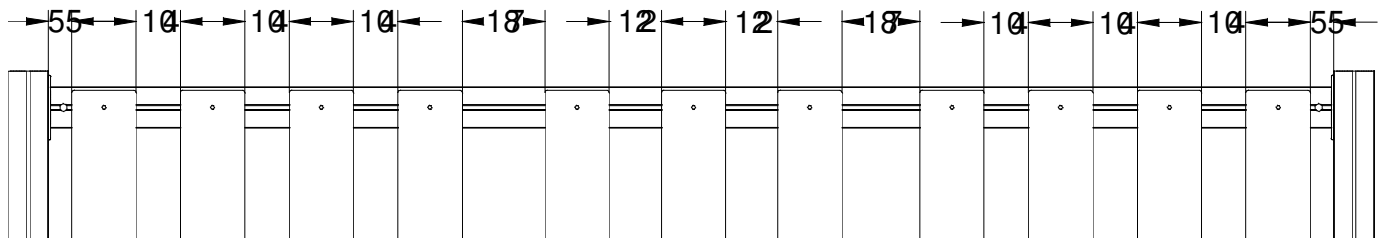
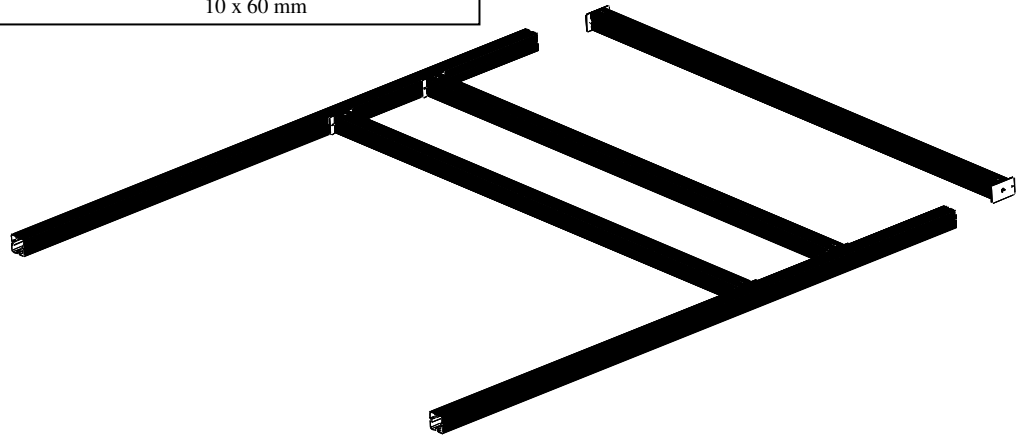
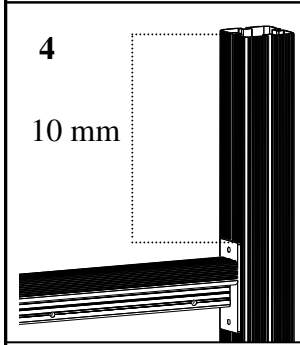
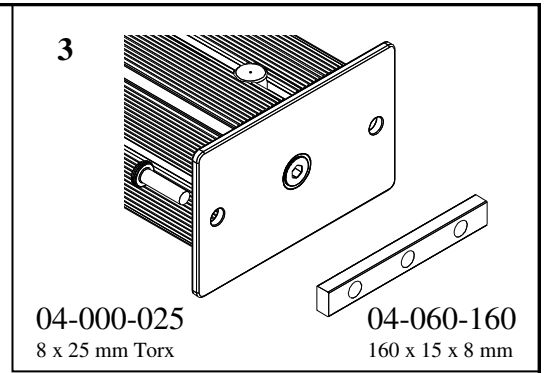
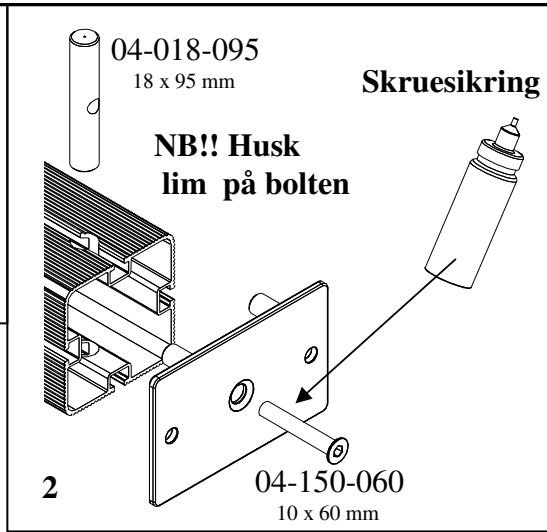
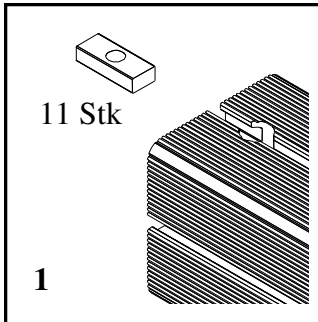

NB! Målt i millimeter

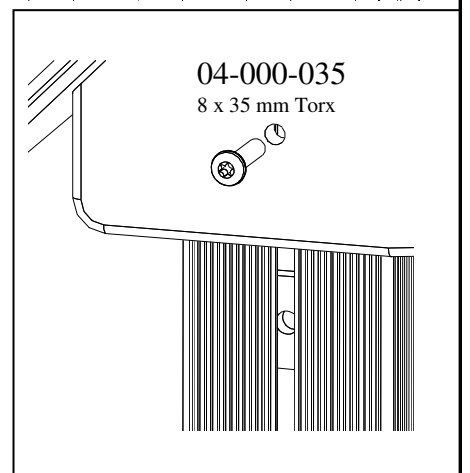
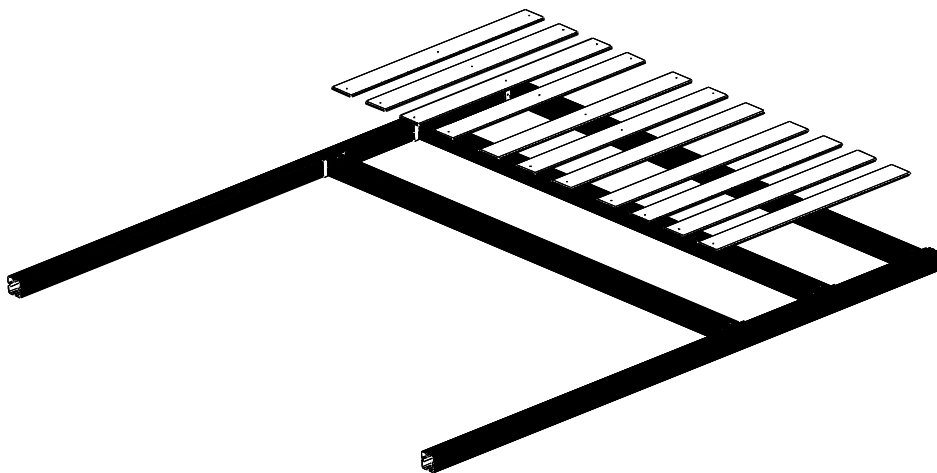

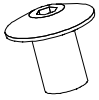

04-030-016  
8 x 16 mm

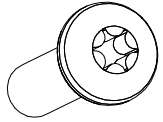
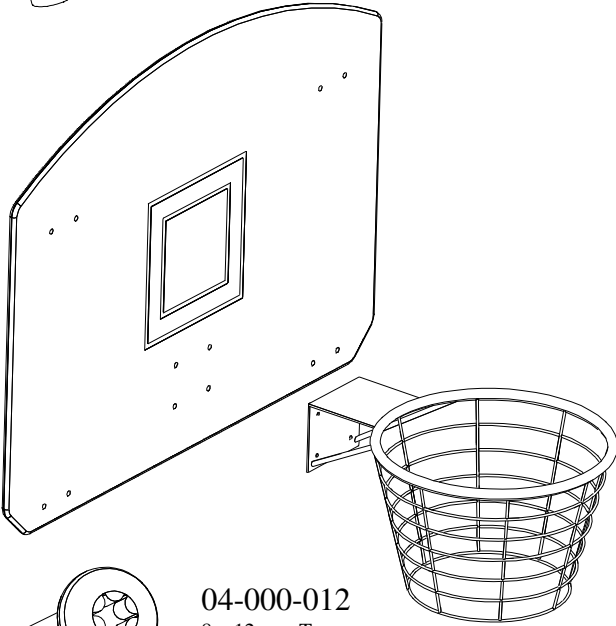

04-000-012  
8 x 12 mm Torx

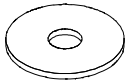

04-050-008  
8 mm

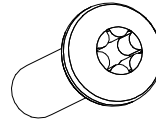

04-000-016  
8 x 16 mm Torx

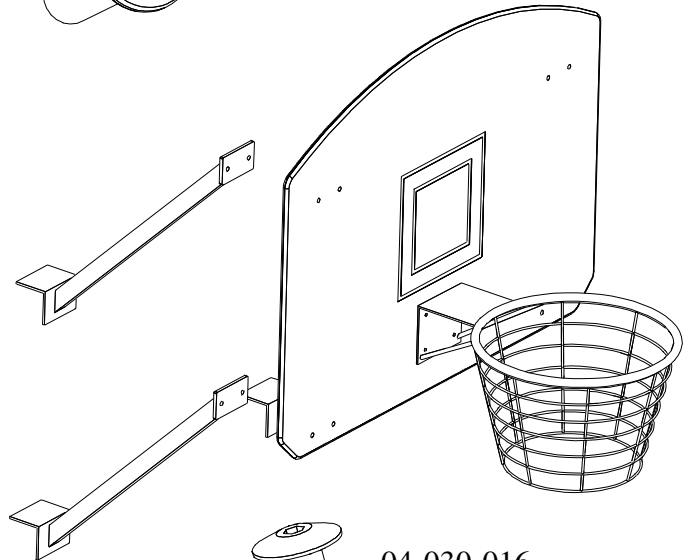

04-030-016  
8 x 16 mm

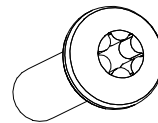



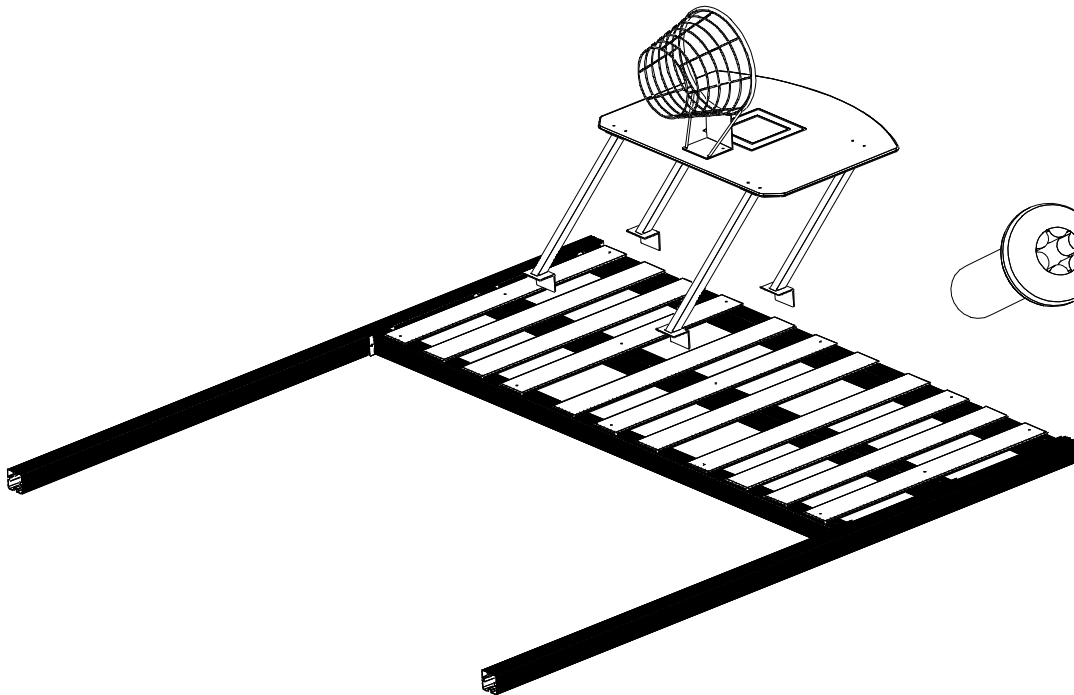

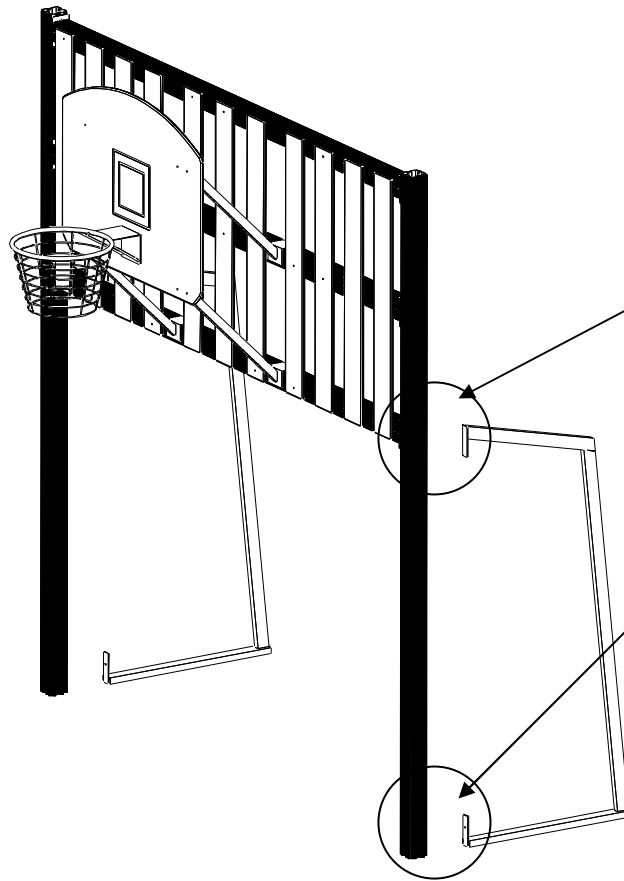
04-000-030  
8 x 30 mm Torx

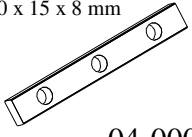
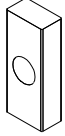



<p><b>04-060-160</b> 160 x 15 x 8 mm</p> 	<p><b>04-000-030</b> 8 x 30 mm Torx</p>
<p><b>04-060-040</b> 40 x 15 x 8 mm</p> 	<p><b>04-000-030</b> 8 x 30 mm Torx</p>

 <p><b>04-010-055</b> 10 x 55 mm</p>
 <p><b>04-055-010</b> 10 mm</p>
 <p><b>04-055-010</b> 10 mm</p>
 <p><b>04-055-010</b> 10 mm</p>
 <p><b>04-040-010</b> 10 mm</p>

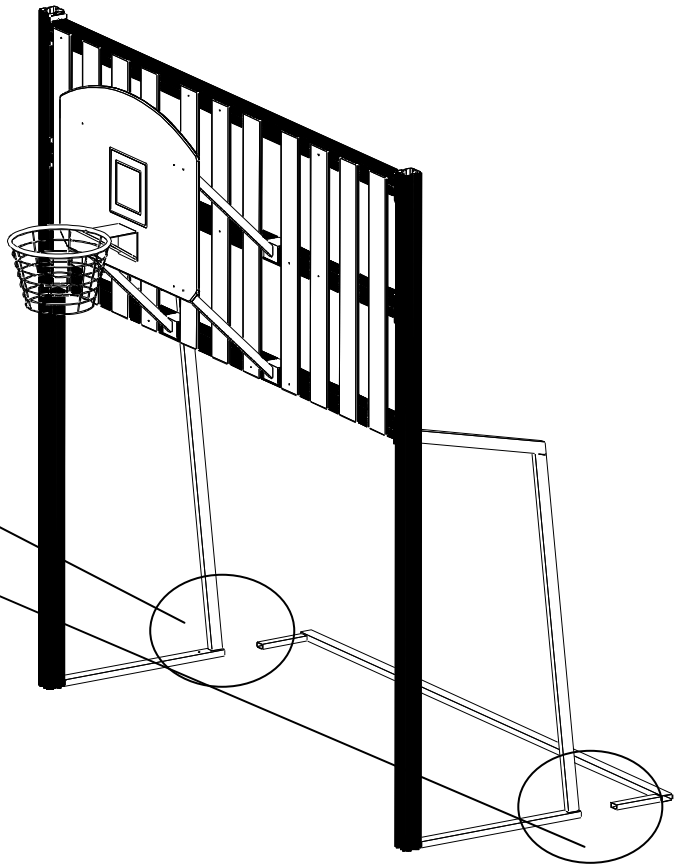

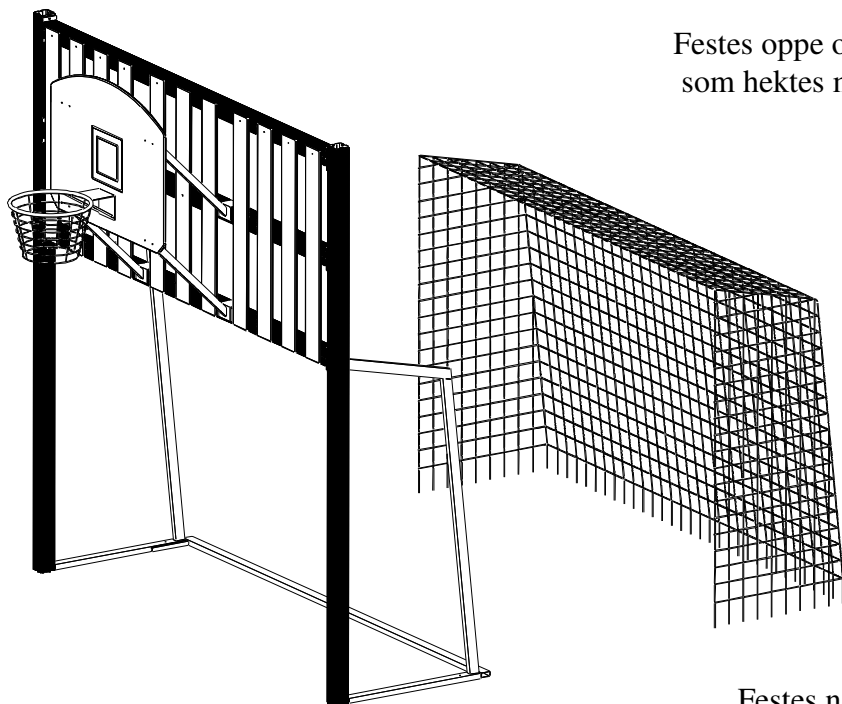

Festes oppe og på sidene med tau som hektes mellom krokene.

Festes nede med tau som strammer opp nettet.

04-060-160  
160 x 15 x 8 mm

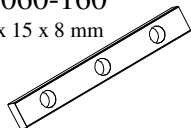

Til feste av langt støttestag

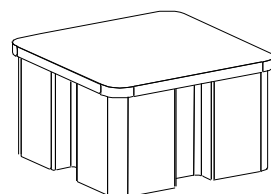
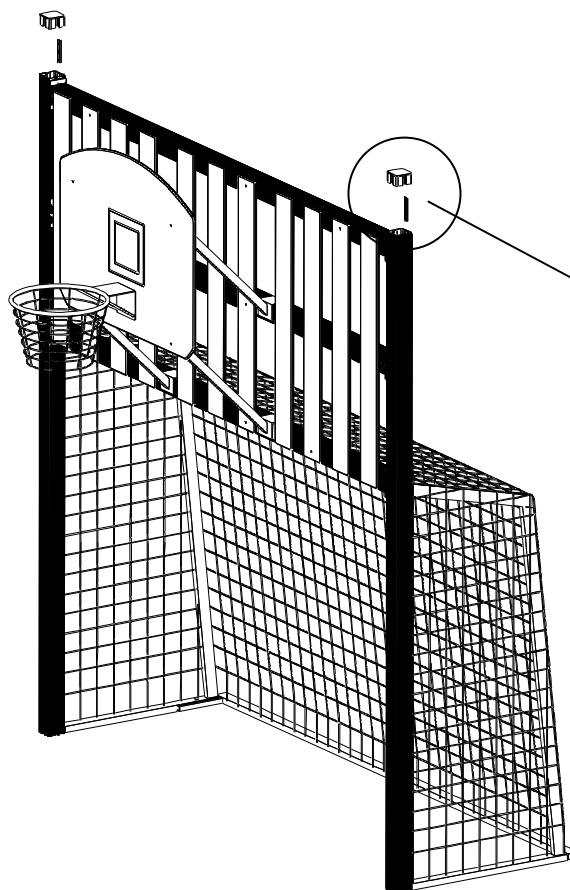

04-060-160  
160 x 15 x 8 mm

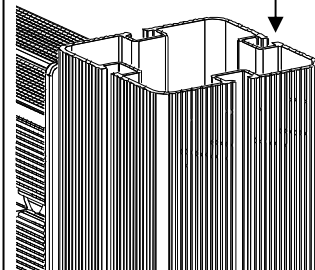
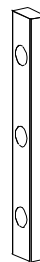

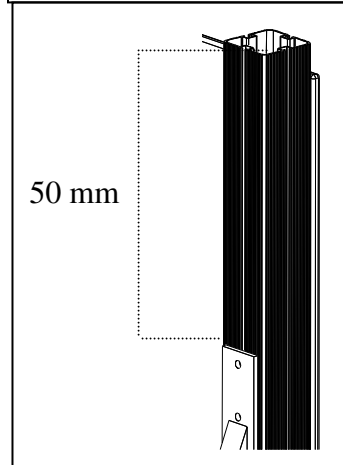
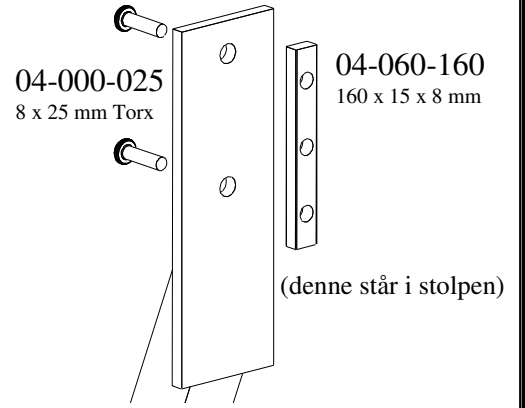
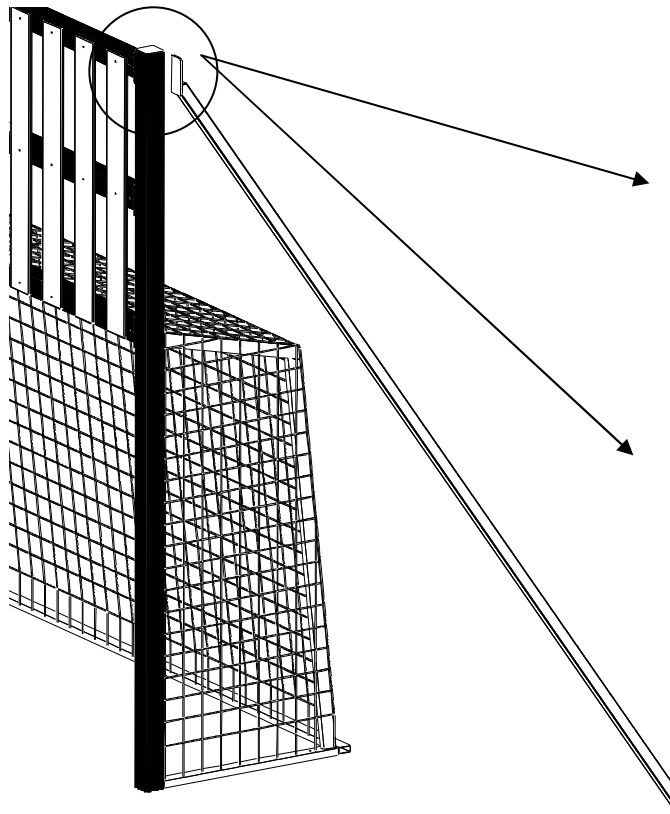

11

## Før utstyret tas i bruk / Before play begins / Innan lekredskapet används

- (N)
- 3 Påse at fallunderlag er lagt i henhold til gjeldende regler eller vår anbefaling
  - 3 Fjern alle monteringshjelpemidler ( rester av betong, planker, paller, plast, og lignende)
  - 3 Før utstyret tas i bruk, sjekk at det ikke er hektefare for anorakksnorer og lignende noen steder på lekeapparatet.

NB! Bør stå i 2-3 dager før bruk når forankring støpes.

- (UK)
- 3 Make sure the area and depth of safer surfacing are according to the current standard, or to the manufacturer's recommendation

3 Make sure all tools and surplus materials are removed before play begins

PS! When complete, allow 2-3 days for the concrete to set before use.









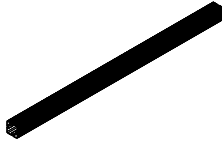
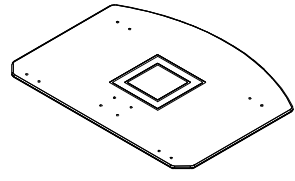
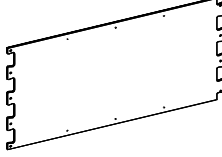

- (S)
- 3 Kontrollera att fallunderlag är utlagt enligt gällande regler eller vår rekommendation
  - 3 Ta bort alla monteringshjälpmedel (rester av betong, plankor, pallar, plast och liknande)
  - 3 Innan lekredskapet används, kontrollera att anoracksnoddar eller kläder/delar av kläder eller liknande inte kan fastna i några delar på redskapet.

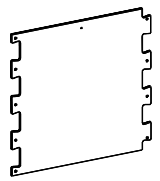
3 OBS! Bör stå i 2-3 dagar innan användning när det gjuts

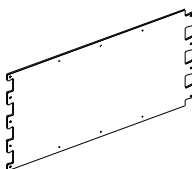
**5****Pakkliste for / Parts list for / Packlista för :  
70-870-010**

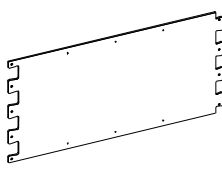
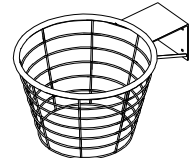
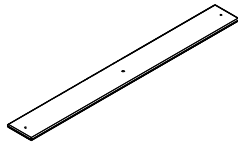
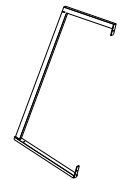
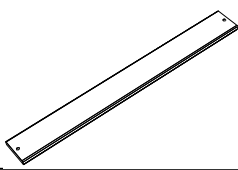
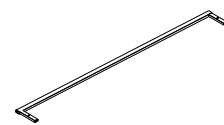
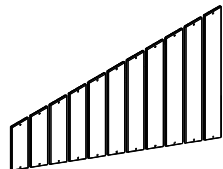
1 av 3

Sign. \_\_\_\_\_

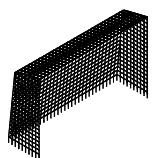
	Komponenter Components Komponenter	Dimensjon Dimension Dimension	Ant Qty Ant	Lev Lev	Komponenter Components Komponenter	Dimensjon Dimension Dimension	Ant Qty Ant	Lev Lev
		4145 x 95x 95 3180 x 95x 95 NB!Hjørnestolper 2990 x 95x 95 2500 x 95x 95 2000 x 95x 95	<b>4</b> <b>12</b> <b>(4)</b> <b>6</b> <b>4</b> <b>21</b>				1200 x 900 x 15	<b>2</b>
	1100 x 2064 x 15	<b>28</b>				1905 x 120 x 40	<b>28</b>	
	1100 x 1064 x 15	<b>1</b>				2070 x 120 x 40	<b>2</b>	
	1100 x 2064 x 15	<b>4</b>				2070 x 120 x 40	<b>2</b>	
	1100 x 2064 x 15	<b>4</b>				640 x 160	<b>2</b>	
	1280 x 150 x 15	<b>22</b>				2143 x 893 x 40	<b>4</b>	
	1022 x 150 x 15	<b>132</b>				3159 x 310 x 30	<b>2</b>	
	 4 av hver  4 of each  4 av hvarje	<b>4</b>					<b>2</b>	











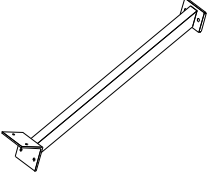
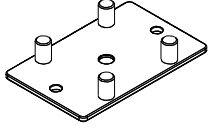

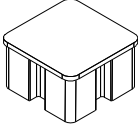
5

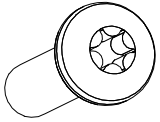
Pakkliste for / Parts list for / Packlista för :  
70-870-010

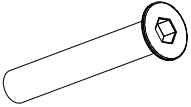
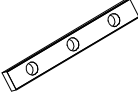
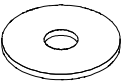
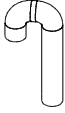
2 av 3

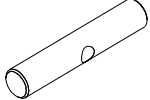
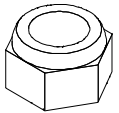
Sign. \_\_\_\_\_

(N) (UK) (S)	Komponenter	Dimensjon	Ant	Lev	Komponenter	Dimensjon	Ant	Lev
	Components	Dimension	Qty	Lev	Components	Dimension	Qty	Lev
(N) (UK) (S)	Komponenter	Dimensjon	Ant	Lev	Komponenter	Dimensjon	Ant	Lev
	Componenter	Dimension	Ant	Lev	Componenter	Dimension	Ant	Lev
		770 x 120 x 120	8			150 x 95 x 25	12	
		2996 x 70	4			55 x 95 x 95	41	
		4940 x 70	4		(N) Produkt merking (UK) Product marking (S) Produkt märkning		1	
(N) (UK) (S)	Bolter/skruer	Dimensjon	Ant	Lev	Bolter/skruer	Dimensjon	Ant	Lev
	Bolts/Screws	Dimension	Qty	Lev	Bultar/Skruvar	Dimension	Qty	Lev
		04-000-012 8 x 12 mm Torx 04-000-016 8 x 16 mm Torx 04-000-025 8 x 25 mm Torx 04-000-030 8 x 30 mm Torx 04-000-035 8 x 35 mm Torx	8 376 128 48 399			04-060-040 40 x 15 x 8 mm	70	
		04-150-060 10 x 60 mm	12			04-060-120 120 x 15 x 8 mm 04-060-160 160 x 15 x 8 mm	88 16	
		04-050-008 8 mm 04-055-010 10 mm	8 8			04-009-025 8 x 25 mm	50	
		04-030-016 8 x 16 mm	376			04-018-095 18 x 95 mm	12	
		04-040-010 10 mm	4			04-010-055 10 x 55 mm	4	
						Skruesikring	1	













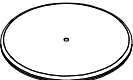

5

Pakkliste for / Parts list for / Packlista för :  
11-145-150

3 av 3

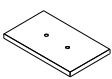
Sign. \_\_\_\_\_

**Forankring / Foundations / Markförankring 00-003-003**

 00-003-100  00-003-101  00-003-102	41	 8 x 35 mm 123
		 8 mm 123
		 120 x 15 x 8 82
00-003-103 	12	 8 x 40 mm 0
		 8 mm 0
		 8 mm 0
Eller Or Eller 00-003-105  00-003-106 	12	 10 x 35 mm 24
		 10 mm 24
		 10 mm 24

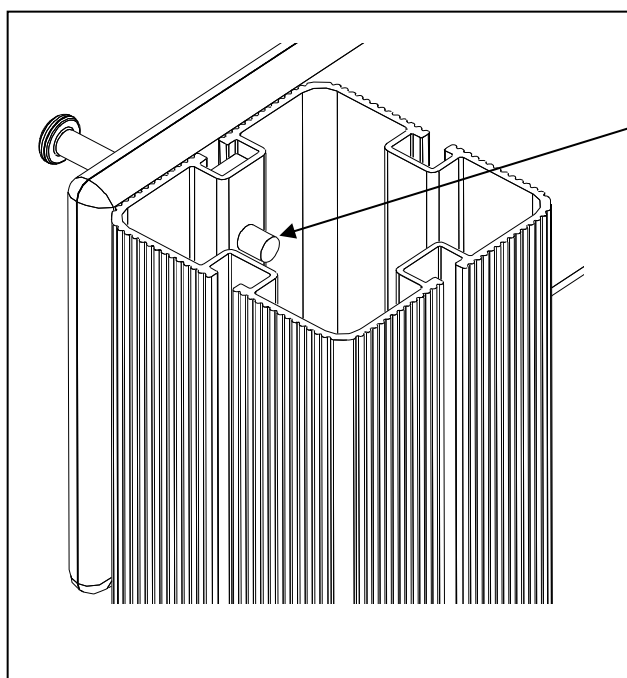

**OBS !**

**Bolten skrues helt igjennom aluminiumen.**

**The bolt must be tightened in to the post, so that it pierces the aluminium.**

**Bulten skruvas helt igenom aluminiumen.**