

Installation guide

YUGO 2

Code: GM0622

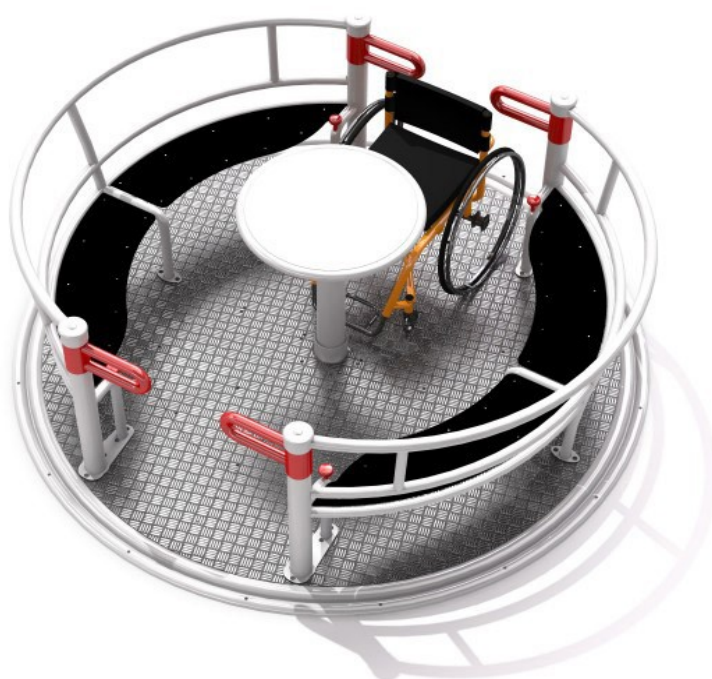

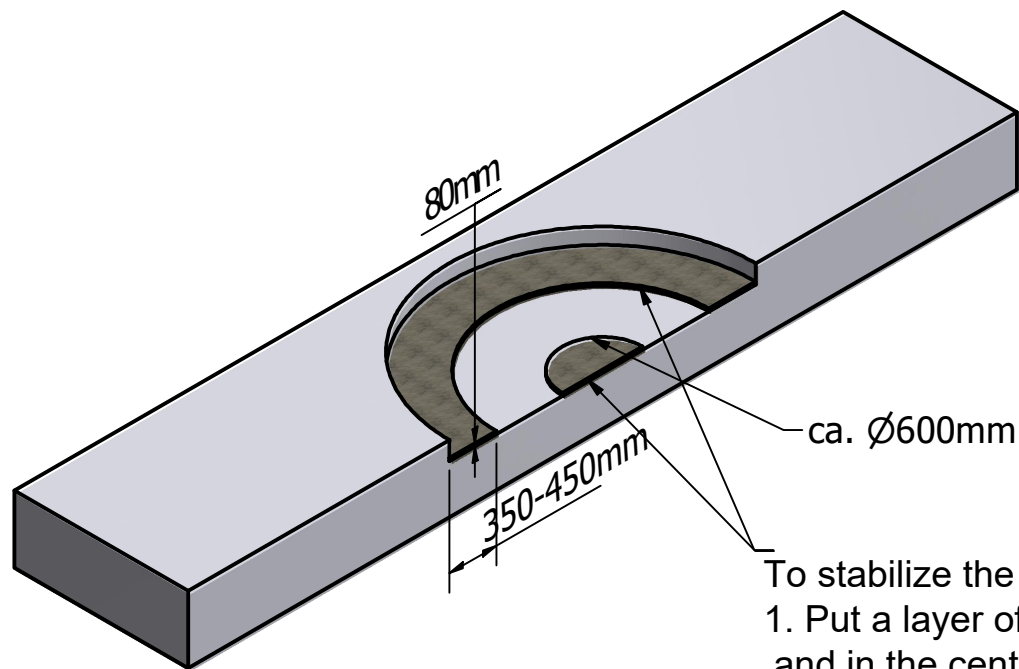
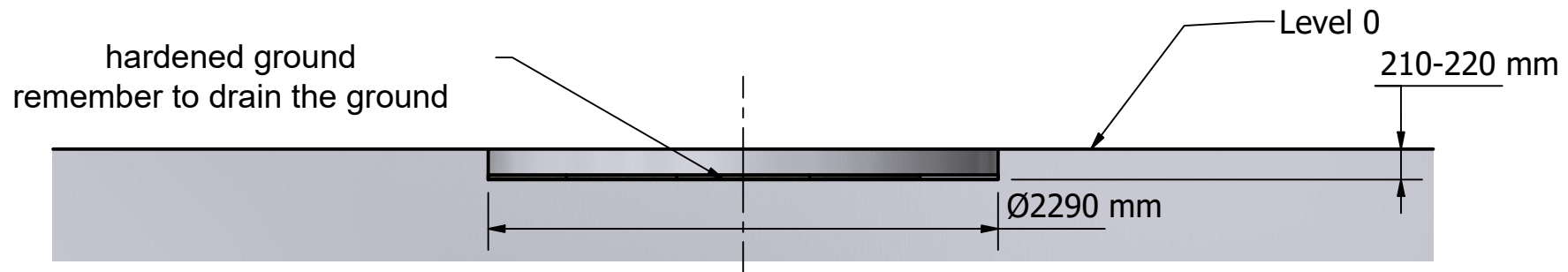

To stabilize the roundabout:

1. Put a layer of dry concrete 80 mm thick around the perimeter and in the centre point of previously prepared foundation hole.
2. Place the roundabout on a layer of dry concrete.

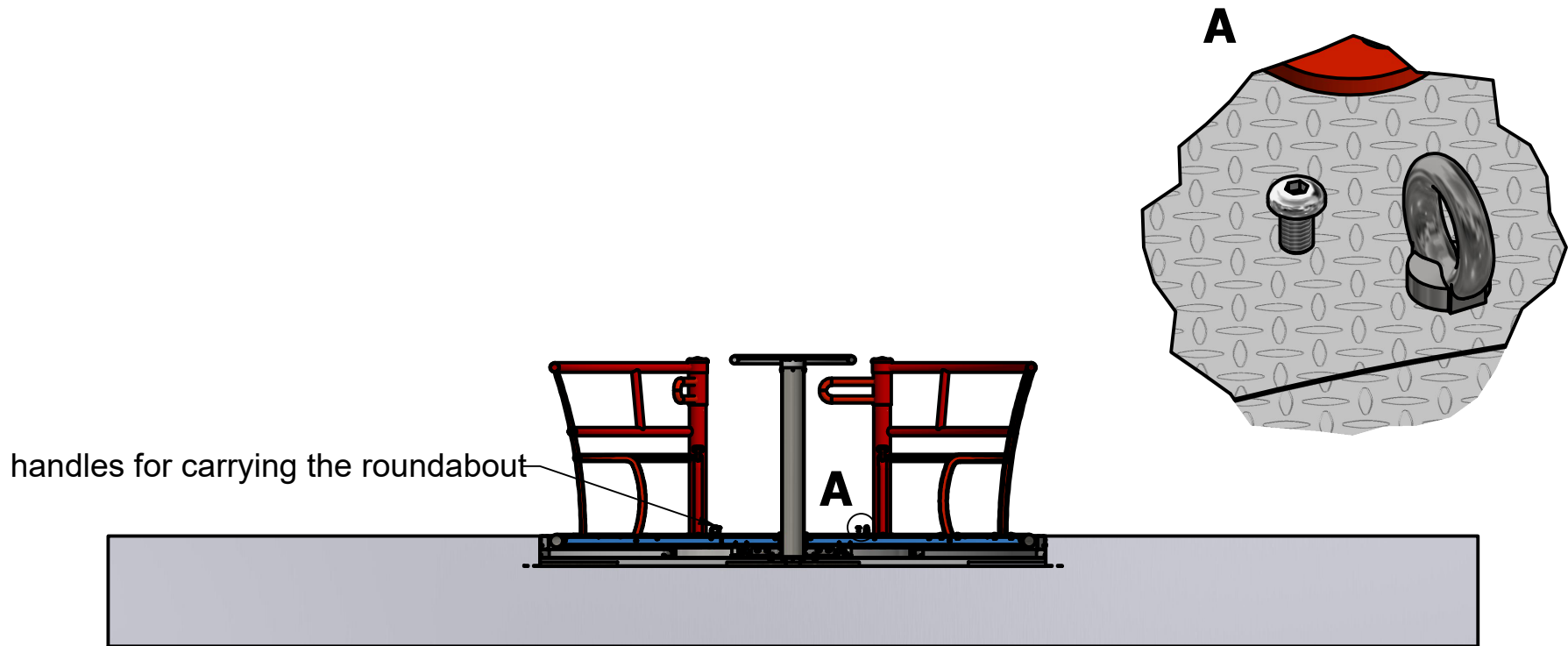

1. The roundabout is fully assembled before delivery.
2. Dig a hole and harden the ground according to the instructions in the drawing. The width of the hole should be slightly larger than the size of the roundabout, this will facilitate assembly.
3. The ground under the roundabout must be water-permeable, hardened and levelled. If the ground is not very stable or weak we recommend strengthening it. It all depends on the quality of the ground at the installation site so, the final decision should always be taken by the construction manager basics on local terms and conditions.
4. **USE THE CRANE!** Place the roundabout in a hole with a crane (use the ring-shaped handles to carry the roundabout).
5. Unscrew the handles and plug the holes with the provided screws.
6. We recommend installing a safe surface around the roundabout to protect users. Required HIC=1m.

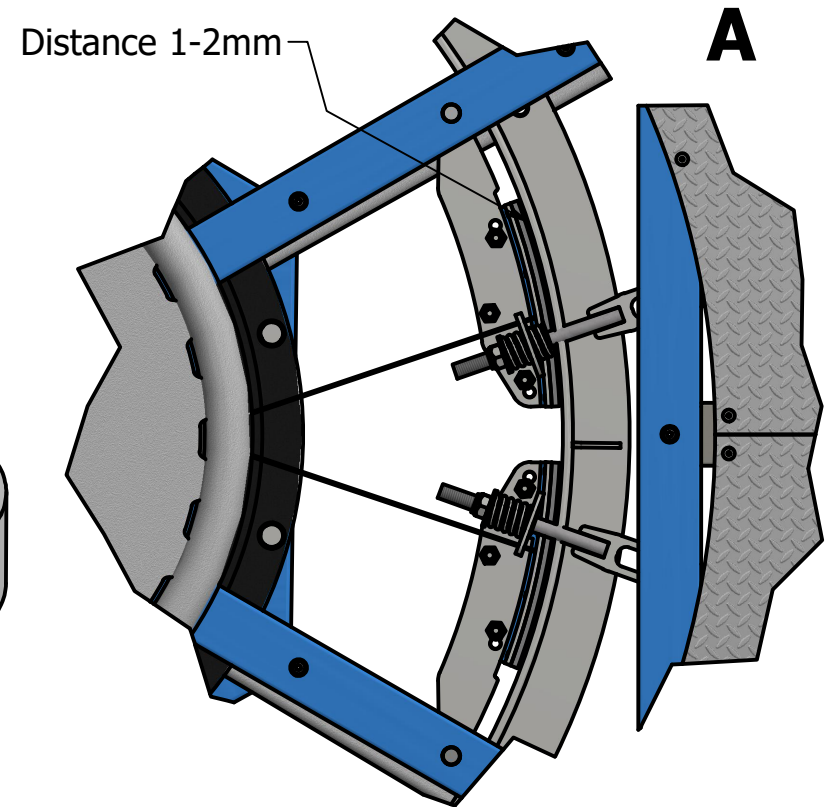
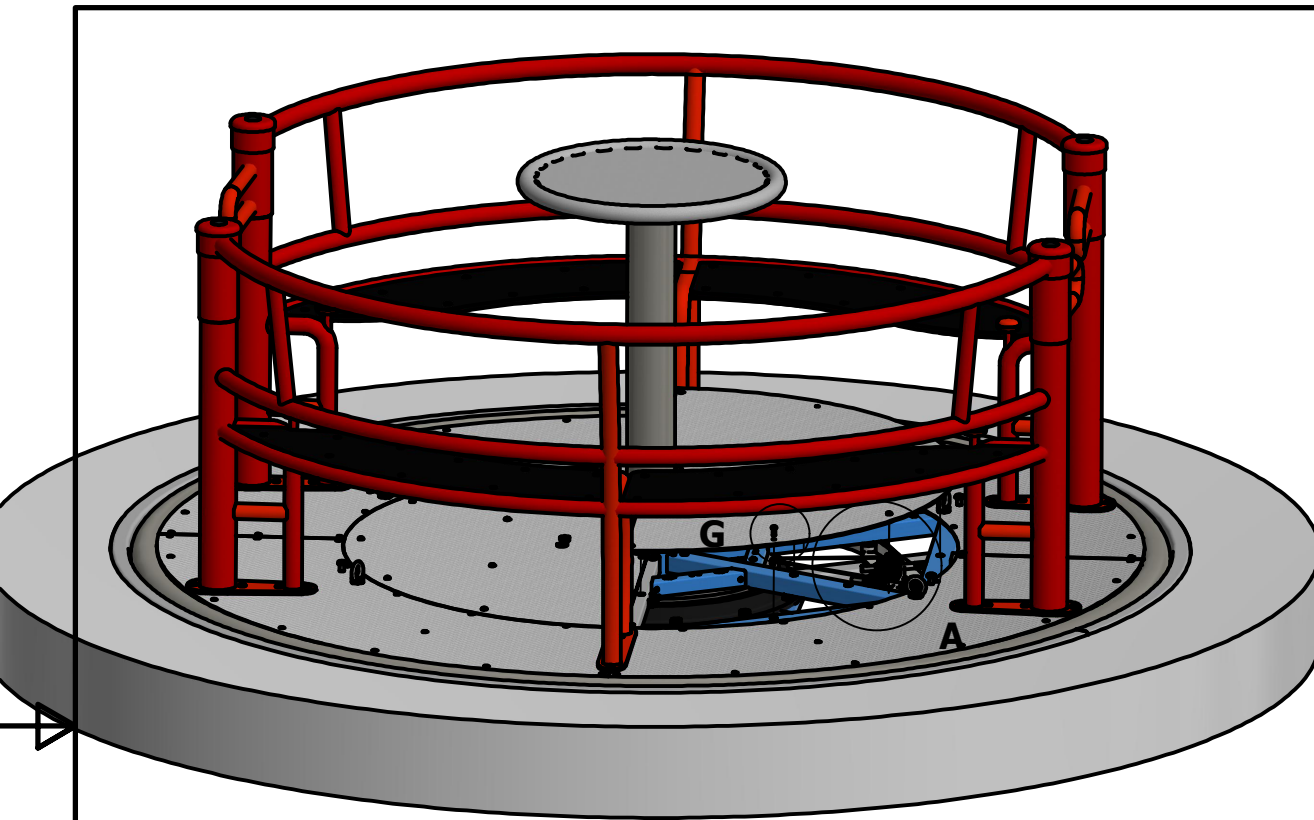

BREAKS ADJUSTMENTS (IF NECESSARY)



1. To adjust the brakes, unscrew and remove the service panel on the floor (detail G).
2. Set the 1-2 mm distance between the frame and brakes using screws (detail A). Properly adjusted brakes must not rub against the frame while the carousel is spinning.
3. Check that the brakes are working properly. Spin the carousel and open one of the gates. The carousel should slowly slow down and stop.
4. After completing the adjustment, screw the service panel back on.

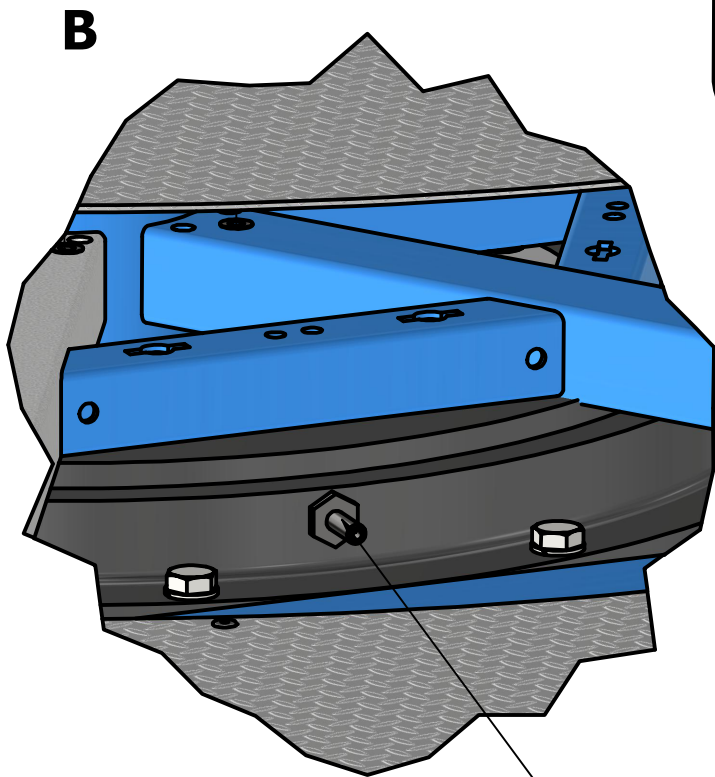
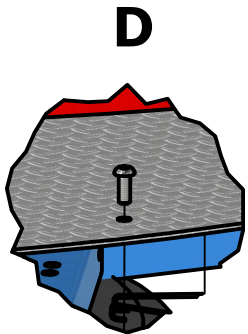

Grease nipple [DIN 71412]

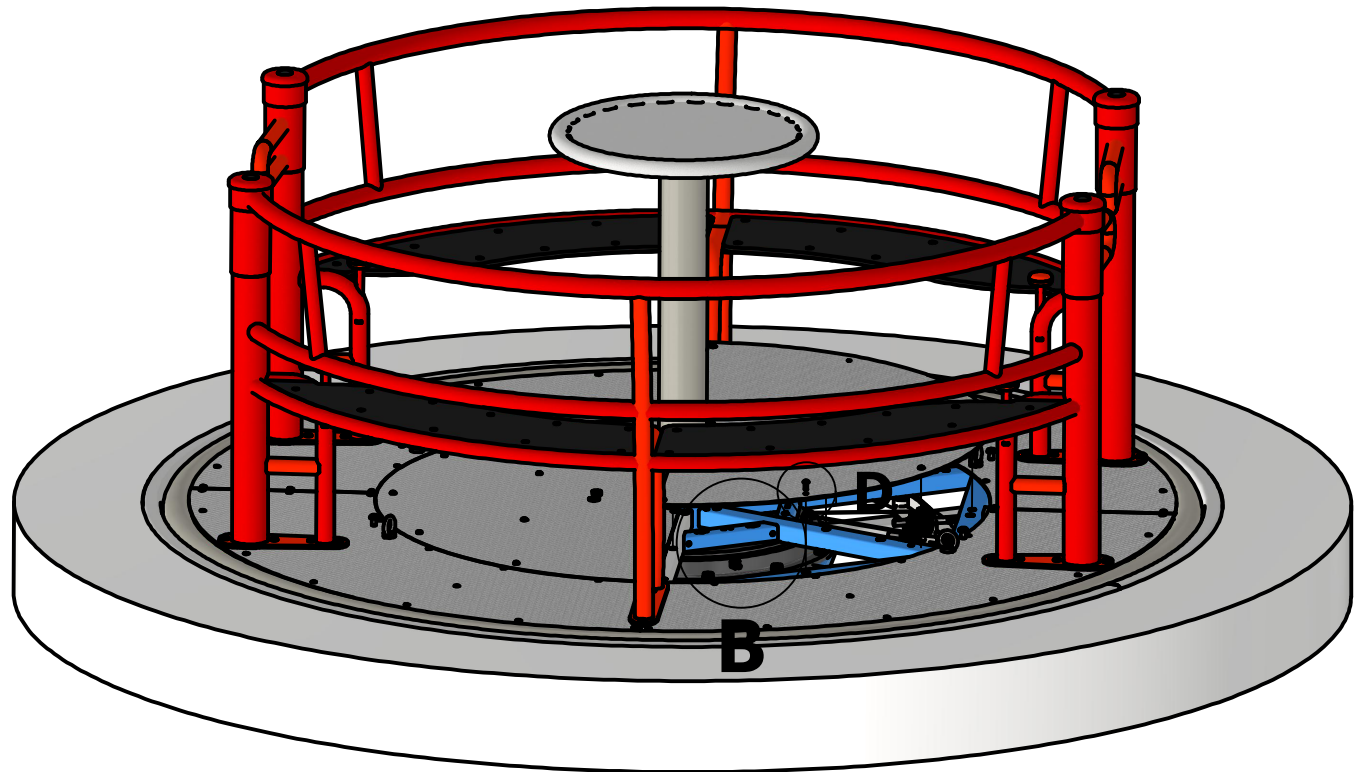

MAINTENANCE – BEARING LUBRICATION (NECESSARILY ONCE A YEAR)

1. To lubricate the bearing, unscrew and remove the service panel on the floor (detail D).
2. Lubricate the bearing with a grease gun, at least once a year (detail B).
3. After completing the lubrication, screw the service panel back on.